



The Ultimate in Fall Protection

CSA Z259.10
Please read this User Manual carefully before using the associated products.

USER INSTRUCTION MANUAL



Figure 1 – ExoFit Strata™ Full Body Harness Models

			SM	MED	LG	XL	2XL	Tri-Lock	Duo-Lock	Tongue Buckle	Belt	Hip Pad	①	②	③	④	⑤
													Suspension Seat	Dorsal	Sternal	Shoulder	Hip
Models			Size					Buckles			Belt & Pad		Attachment Elements				
1112535C - 1112539C	1112540C - 1112544C	1112545C - 1112549C	✓					✓			✓	✓		✓			✓
				✓				✓			✓	✓		✓			✓
					✓			✓			✓	✓		✓			✓
			✓					✓			✓	✓		✓	✓		✓
				✓				✓			✓	✓		✓	✓		✓
					✓			✓			✓	✓		✓	✓	✓	✓
								✓			✓	✓		✓			✓
			✓					✓			✓	✓		✓	✓		✓
				✓				✓			✓	✓		✓	✓		✓
								✓			✓	✓		✓	✓		✓
					✓			✓			✓	✓		✓	✓	✓	✓
			✓					✓			✓	✓		✓			✓
				✓				✓			✓	✓		✓			✓
								✓			✓	✓		✓	✓		✓
			✓					✓			✓	✓		✓	✓		✓
					✓			✓			✓	✓		✓	✓	✓	✓
								✓			✓	✓		✓	✓	✓	✓

Figure 1 – ExoFit Strata™ Full Body Harness Models

		SM	MED	LG	XL	2XL	Tri-Lock	Duo-Lock	Tongue Buckle	Belt	Hip Pad	①	②	③	④	⑤
		Size					Buckles			Belt & Pad		Attachment Elements				
Models												Suspension Seat	Dorsal	Sternal	Shoulder	Hip
1112580C - 1112584C	1112585C - 1112589C	✓					✓			✓	✓	✓	✓	✓	✓	✓
1112581C			✓				✓			✓	✓	✓	✓	✓	✓	✓
1112582C				✓			✓			✓	✓	✓	✓	✓	✓	✓
1112583C					✓		✓			✓	✓	✓	✓	✓	✓	✓
1112584C						✓	✓			✓	✓	✓	✓	✓	✓	✓
1112585C		✓					✓		✓	✓	✓	✓	✓	✓	✓	✓
1112586C			✓				✓		✓	✓	✓	✓	✓	✓	✓	✓
1112587C				✓			✓		✓	✓	✓	✓	✓	✓	✓	✓
1112588C					✓		✓		✓	✓	✓	✓	✓	✓	✓	✓
1112589C						✓	✓		✓	✓	✓	✓	✓	✓	✓	✓

Figure 2 – ExoFit Strata™ Harness Components

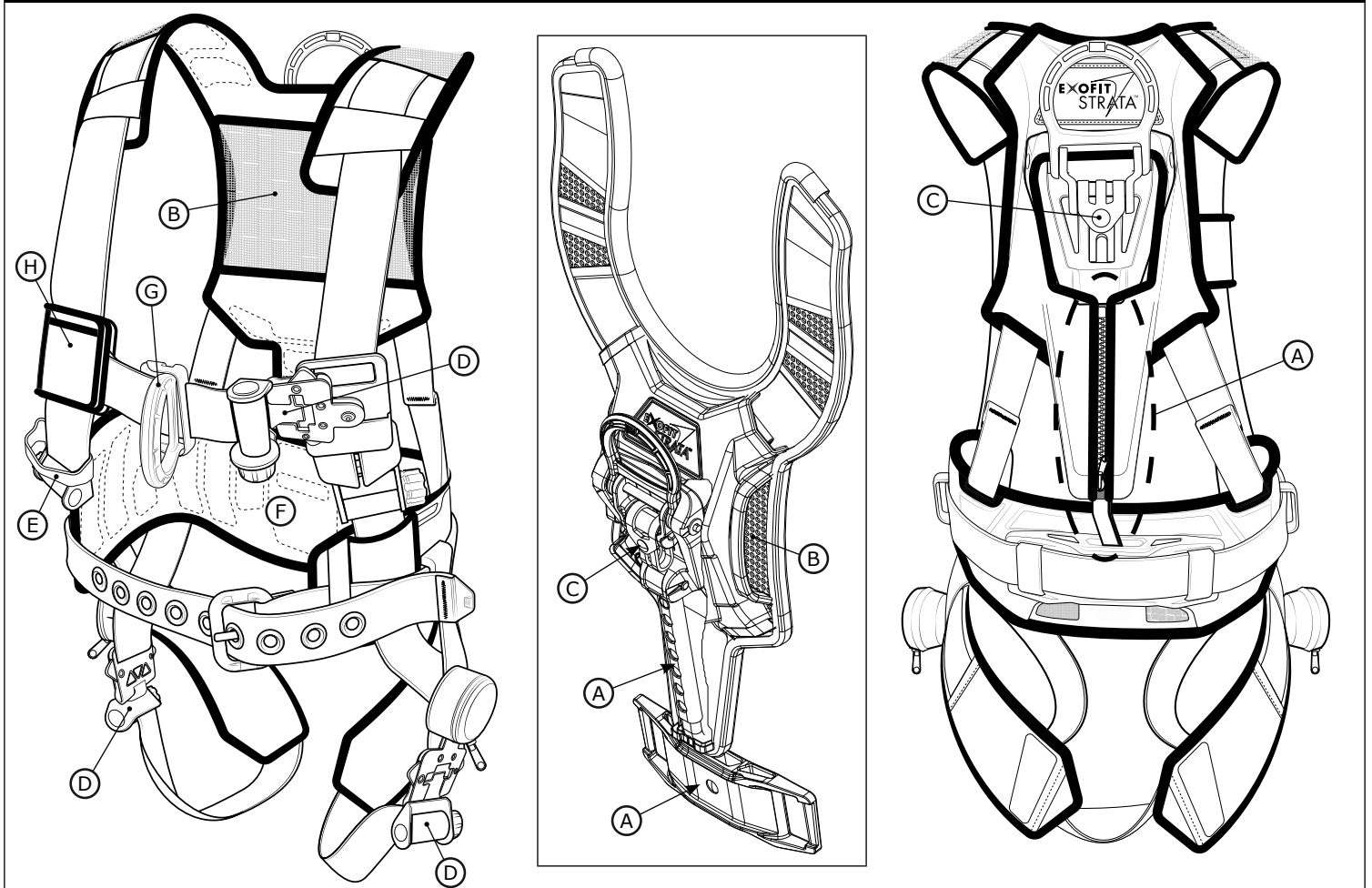

A - LIFTech™ Weight Distribution System **B** - PolarMesh™ Back Pad **C** - EZ-Link™ Personal SRL Adapter **D** - Tri-Lock Revolver™ Buckles
E - Break-Away Auto-Reset Lanyard Keepers **F** - EVA Thermoformed Hip Pad **G** - Store-Away Sternal D-Ring **H** - Personalization Pocket

DANGER: This product is part of a personal fall arrest, restraint, work positioning, personnel riding, climbing, or rescue system. The user must follow the manufacturer's instructions for each component of the system. These instructions must be provided to the user of this equipment. The user must read and understand these instructions before using this equipment. Manufacturer's instructions must be followed for proper use and maintenance of this equipment. If this product is resold outside the original country of destination, the re-seller must provide these instructions in the language of the country in which the product will be used. Alterations or misuse of this product or failure to follow instructions may result in serious injury or death.

IMPORTANT: If you have questions on the use, care, or suitability of this equipment for your application, contact Capital Safety.

IMPORTANT: Before using this equipment, record the product identification information from the ID label in the inspection and maintenance log of this manual.

DESCRIPTION

Figure 1 defines available ExoFit Strata™ Full Body Harness models. ExoFit Strata Harnesses include various combinations of the following features on previous DBI-SALA Full Body Harnesses:

- Tech-Lite™ Aluminum D-Rings - Varied Locations: Dorsal, Sternal, Shoulder, Hip, and Suspension Seat
- Duo-Lok™ Quick Connect Buckles
- Tongue Buckle Leg Straps
- Tongue Buckle Body Belt
- Repel™ Technology Webbing
- Hybrid Comfort Padding
- Lumbar Pad
- Revolver™ Adjusters
- Suspension Trauma Straps

In addition, ExoFit Strata Harness models include the following new innovations (illustrated in Figure 2):

- LIFTech™ Weight Distribution System (A)
- PolarMesh™ Back Pad (B)
- EZ-Link™ Personal SRL Adapter (C)
- Tri-Lock Revolver™ Buckles (D)
- Break-Away Auto-Reset Lanyard Keepers (E)
- EVA Thermoformed Hip Pad (F)
- Store-Away Sternal D-Ring (G)
- Personalization Pocket (H)





SPECIFICATIONS

Performance:	
Maximum Free Fall Distance	6 ft (1.8 m)
Maximum Arresting Force	1,800 lbs (13 kN)
Capacity	CSA Z259.10 Maximum Capacity: 352 lbs (160 kg) OSHA Maximum Capacity: 420 lbs (191 kg)

Materials:	
Webbing	Polyester - 6,000 lbs (27 kN) Tensile Strength
Padding and Label Cover	Nylon, Polyester, Polyurethane, EVA, Vinyl
Thread	Polyester Thread on Polyester Webbing
Tech-Lite D-Rings	Aluminum Alloy - 5,000 lbs (22 kN) Tensile Strength
Duo-Lok Connectors	Aluminum Alloy, Stainless Steel, and Alloy Steel - 4,000 lbs (18 kN) Tensile Strength
Tri-Lok Connectors	Aluminum Alloy, Stainless Steel, and Alloy Steel - 4,000 lbs (18 kN) Tensile Strength
Revolver Adjusters	Aluminum Alloy, Stainless Steel, Alloy Steel, and Nylon - 4,000 lbs (18 kN) Tensile Strength

1.0 APPLICATIONS

1.1 **PURPOSE:** Full Body Harnesses are to be used as components in Personal Fall Protection System designed to prevent a fall or safely arrest a fall. Full Body Harnesses are used in the following applications:

Application	CSA Class	Description
Personal Fall Arrest	Class A 	The full body harness is used as a component of a personal fall arrest system. Personal fall arrest systems typically include a full body harness and a connecting subsystem (energy absorbing lanyard). Maximum arresting force must not exceed 1,800 lbs (8 kN). For fall arrest applications connect the fall arrest subsystem (example: lanyard, SRL, energy absorber, etc.) to the D-Ring or attachment element on your back, between your shoulder blades.
Controlled Descent	Class D 	For controlled descent applications, harnesses equipped with a single sternal level D-ring, one or two frontal mounted D-rings, or a pair of connectors originating below the waist (such as a seat sling) may be used for connection to a descender or evacuation system (reference in Z259.10 in Canada).
Rescue	Class E 	The full body harness is used as a component of a rescue system. Rescue systems are configured depending on the type of rescue. For limited access (confined space) applications, harnesses equipped with D-Rings on the shoulders may be used for entry and egress into confined spaces where worker profile is an issue.
Ladder Climbing	Class L 	The full body harness is used as a component of a climbing system to prevent the user from falling when climbing a ladder or other climbing structure. Climbing systems typically include a full body harness, vertical cable or rail attached to the structure, and climbing sleeve. For ladder climbing applications, harnesses equipped with a frontal D-Ring in the sternal location may be used for fall arrest on fixed ladder climbing systems. These are defined in CSA Z259.2.5 in Canada and ANSI A14.3 in the United States.
Work Positioning	Class P 	The full body harness is used as a component of a work positioning system to support the user at a work position. Work positioning systems typically include a full body harness, positioning lanyard, and a back-up personal fall arrest system. For work positioning applications, connect the work positioning subsystem (example: lanyard, Y-lanyard, etc.) to the lower (hip level) side or belt mounted work positioning attachment anchorage elements (D-rings). Never use these connection points for fall arrest.
Restraint	None	The full body harness is used as a component of a restraint system to prevent the user from reaching a fall hazard. Restraint systems typically include a full body harness and a lanyard or restraint line.

⚠ CAUTION: Certain application and work conditions require the use of Full Body Harnesses with specific attributes:

- Full body harnesses with Kevlar® web should be used when working with tools, materials, or environments of high temperature (foundries, chemical manufacturing, steel fabrication, emergency rescue services, fire services, welders, oil industry, nuclear industry, explosives).
- Harnesses with PVC coated hardware should be used when working in explosive or electrically conductive environments, or where surfaces must be protected from the hardware.
- Harnesses with high visibility webbing should be used when increased visibility of the user is required.

1.2 **STANDARDS:** Harnesses included in this manual conform to the standard(s) identified on the front cover of this instruction.

1.3 **TRAINING:** It is the responsibility of the user and the purchaser of this equipment to assure that they are familiar with these instructions, trained in the correct care and use of, and are aware of the operating characteristics, application limits, and the consequences of improper use of this equipment.

⚠ CAUTION: Training must be conducted without exposing the user to a fall hazard. Training should be repeated on a periodic basis.

1.4 **LIMITATIONS:** Always consider the following application limitations before using this equipment:

- **CAPACITY:** The Full Body Harness is designed for use by persons with a maximum combined weight (clothing, tools, etc.) of 352 lbs (160 kg). Make sure all of the components in your system are rated to a capacity appropriate to your application.

① NOTE: 352lbs (160 kg) is the maximum capacity allowed by CSA Z259.10. Capital safety harnesses are factory tested to a maximum OSHA capacity of 420 lbs (191 kg).

- **FREE FALL:** Personal fall arrest systems used with this equipment must be rigged to limit the free fall to 6 feet (1.8 m). Restraint systems must be rigged so that no vertical free fall is possible. Work positioning systems must be rigged so that free fall is limited to 2 feet (.6 m) or less. Personnel riding systems must be rigged so that no vertical free fall is possible. Climbing systems must be rigged so that free fall is limited to 18 in. (.46 m) or less. Rescue systems must be rigged so that no vertical free fall is possible. See subsystem manufacturer's instructions for more information.

- **FALL CLEARANCE:** Figure 3 illustrates the components of a Fall Arrest. There must be sufficient clearance below the user to arrest a fall before the user strikes the ground or other obstruction. Clearance is affected by a number of factors including the following parameters:

Elevation of Anchorage	Free Fall Distance	Worker Height
Connecting Subsystem Length	Deceleration Distance	Attachment Element Movement and Harness Stretch

① **NOTE:** Refer to the instructions included with your Fall Arrest subsystem for specifics regarding Fall Clearance calculation.

- **SWING FALLS:** Swing Falls occur when the anchorage point is not directly above the point where a fall occurs (see Figure 4). The force of striking an object in a swing fall may cause serious injury or death. Minimize swing falls by working as directly below the anchorage point as possible. Do not permit a swing fall if injury could occur. Swing falls will significantly increase the clearance required when a Self-Retracting Device or other variable length connecting subsystem is used.
- **EXTENDED SUSPENSION:** A Full Body Harness is not intended for use in extended suspension applications. If the user is going to be suspended for an extended length of time it is recommended that some form of seat support be used. Capital Safety recommends a seat board, suspension work seat, seat sling, or a boatswain chair. Contact Capital Safety for more information on these items.
- **ENVIRONMENTAL HAZARDS:** Use of this equipment in areas with environmental hazards may require additional precautions to prevent injury to the user or damage to the equipment. Hazards may include, but are not limited to; heat, chemicals, corrosive environments, high voltage power lines, gases, moving machinery, and sharp edges.
- **HARNESSES FOR HIGH TEMPERATURE ENVIRONMENTS:** Harnesses with Kevlar® webbing are designed for use in high temperature environments, with limitations: Kevlar® webbing begins to char at 800° to 900° Fahrenheit. Kevlar® webbing can withstand limited contact exposure to temperatures up to 1,000° F. Polyester webbing loses strength at 300° to 400° F. PVC coating on hardware has a melting point of approximately 350° F.

⚠ **WARNING:** When working with tools, materials, or in high temperature environments, ensure that associated fall protection equipment can withstand high temperatures, or provide protection for those items.

⚠ **WARNING:** Although PVC coated and zinc plated hardware exhibit excellent corrosion resistance in chemical, acidic, alkaline, and atmospheric conditions, frequent inspections may be required. Consult with Capital Safety if you question the use of this equipment in hazardous environments.

Figure 3 – Fall Arrest Components

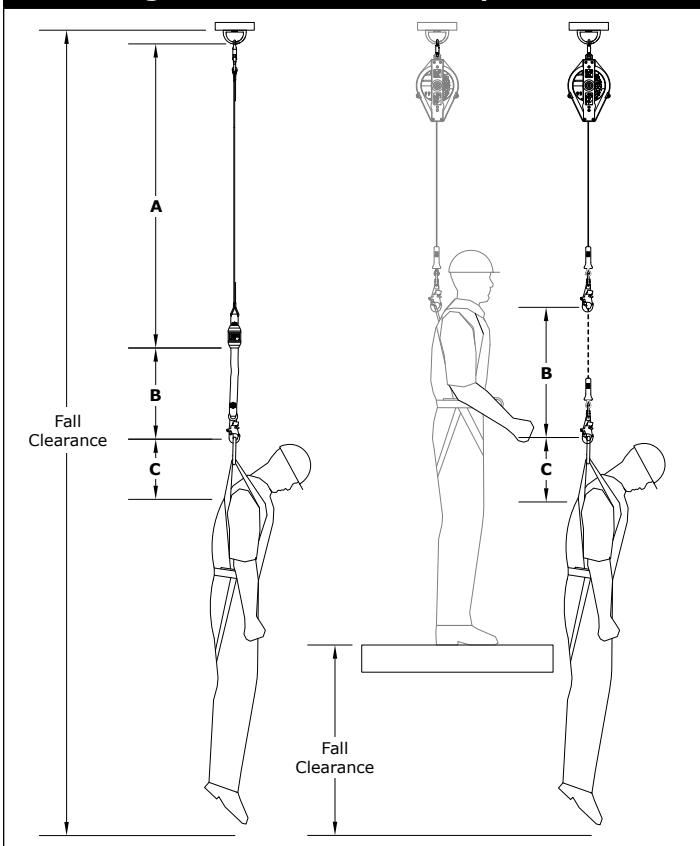
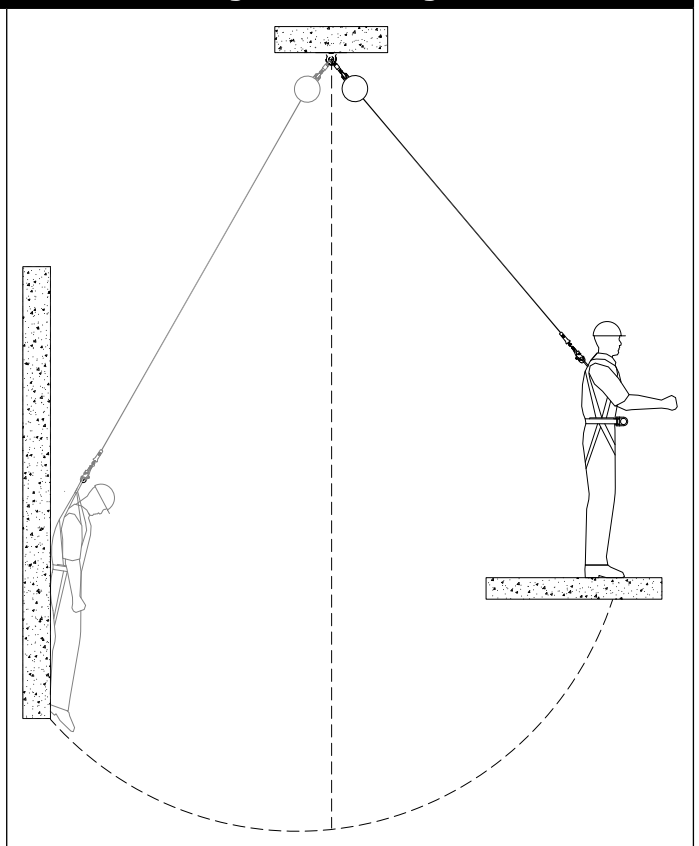

Figure 4 – Swing Fall



- A** - Lanyard Length
- B** - Lanyard Deceleration Distance or SRL Maximum Arrest Distance
- C** - Safety Factor = Harness Stretch (H_c) + D-Ring/Connector Length + Settling = 1.5 ft (0.5 m)

2.0 SYSTEM USE

- 2.1 RESCUE PLAN:** When using this equipment and connecting subsystem(s), the employer must have a rescue plan and the means at hand to implement and communicate that plan to users¹, authorized persons², and rescuers³.
- 2.2 INSPECTION FREQUENCY:** The Full Body Harness shall be inspected by the user before each use and by a competent person⁴ other than the user at intervals of no more than one year⁵. Inspection procedures are described in the *User Instruction Manual's "Inspection and Maintenance Log"*. Results of each Competent Person inspection should be recorded on copies of the *"Inspection and Maintenance Log"* or tracked with the i-Safe™ system (see *"Inspection"*).
- 2.3 COMPATIBILITY OF COMPONENTS:** Capital Safety equipment is designed for use with Capital Safety approved components and subsystems only. Substitutions or replacements made with non-approved components or subsystems may jeopardize compatibility of equipment and may effect the safety and reliability of the complete system.
- 2.4 COMPATIBILITY OF CONNECTORS:** Connectors are compatible with connecting elements when they have been designed to work together in such a way that their sizes and shapes do not cause their gate mechanisms to inadvertently open regardless of how they become oriented. Contact Capital Safety if you have any questions about compatibility. Connectors (hooks, carabiners, and D-Rings) must be capable of supporting at least 5,000 lbs. (22.2 kN). Connectors must be compatible with the anchorage or other system components. Do not use equipment that is not compatible. Non-compatible connectors may unintentionally disengage (See Figure 5). Connectors must be compatible in size, shape, and strength. If the connecting element to which a snap hook (shown) or carabiner attaches is undersized or irregular in shape, a situation could occur where the connecting element applies a force to the gate of the snap hook or carabiner. This force may cause the gate (of either a self-locking or a non-locking snap hook) to open, allowing the snap hook or carabiner to disengage from the connecting point. Self-locking snap hooks and carabiners are required.
- 2.5 MAKING CONNECTIONS:** Use only self-locking snap hooks and carabiners with this equipment. Use only connectors that are suitable for each application. Ensure all connections are compatible in size, shape and strength. Do not use equipment that is not compatible. Ensure all connectors are fully closed and locked.

Capital Safety connectors (snap hooks and carabiners) are designed to be used only as specified in each product's user's instructions. See Figure 6 for inappropriate connections. Capital Safety snap hooks and carabiners should not be connected:

- A. To a D-Ring to which another connector is attached.
- B. In a manner that would result in a load on the gate.

⚠ CAUTION: Large throat snap hooks should not be connected to standard size D-Rings or similar objects which will result in a load on the gate if the hook or D-Ring twists or rotates, unless the snap hook complies with CSA Z259.12 and is equipped with a 3,600 lb (16 kN) gate. Check the marking on your snap hook to verify that it is appropriate for your application.

- C. In a false engagement, where features that protrude from the snap hook or carabiner catch on the anchor, and without visual confirmation seems to be fully engaged to the anchor point.
- D. To each other.
- E. Directly to webbing or rope lanyard or tie-back (unless the manufacturer's instructions for both the lanyard and connector specifically allows such a connection).
- F. To any object which is shaped or dimensioned such that the snap hook or carabiner will not close and lock, or that roll-out could occur.
- G. In a manner that does not allow the connector to align properly while under load.

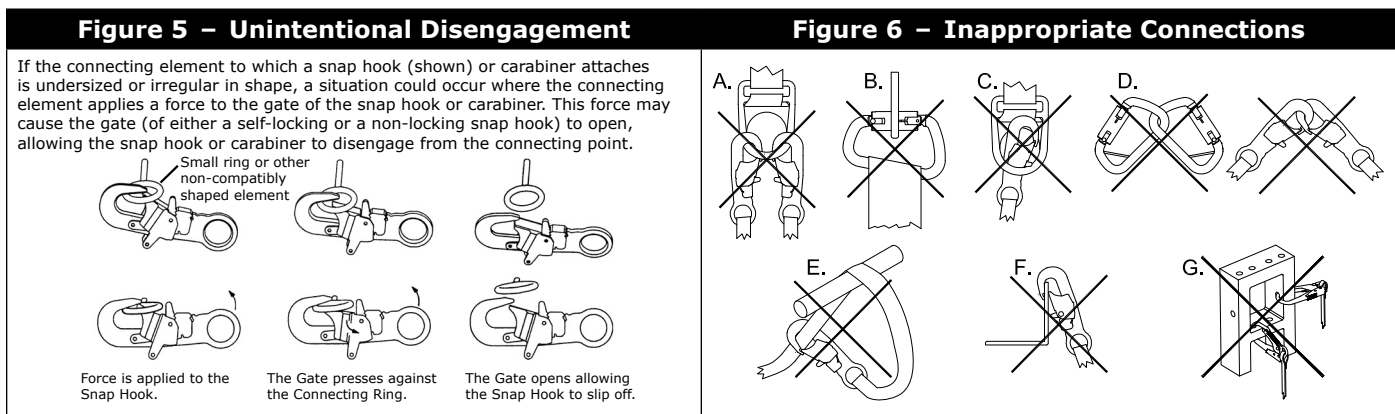

- 1 User:** A person who performs activities at heights while protected by a personal fall protection system.
- 2 Authorized Person:** A person assigned by the employer to perform duties at a location where the person will be exposed to a fall hazard.
- 3 Rescuer:** Person or persons other than the rescue subject acting to perform an assisted rescue by operation of a rescue system.
- 4 Competent Person:** One who is capable of identifying existing and predictable hazards in the surroundings or working conditions which are unsanitary, hazardous, or dangerous to employees, and who has authorization to take prompt corrective measures to eliminate them.
- 5 Inspection Frequency:** Extreme working conditions (harsh environments, prolonged use, etc.) may require increasing the frequency of competent person inspections.

2.6 CONNECTING SUBSYSTEMS: Connecting subsystems (self-retracting lifeline, lanyard, rope grab and lifeline, cable sleeve, etc.) must be suitable for your application (See section 1.1). See the subsystem manufacturer's instructions for additional information. Some harness models have web loop connection points. Do not use snap hooks to connect to web loops. Use a self-locking carabiner to connect to a web loop. Ensure the carabiner cannot cross-gate load (load against the gate rather than along the major axis of the carabiner). Some lanyards are designed to choke onto a web loop to provide a compatible connection. Lanyards may be sewn directly to the web loop forming a permanent connection. Do not make multiple connections onto one web loop, unless choking two lanyards onto a properly sized web loop. To choke the lanyard on a web loop:

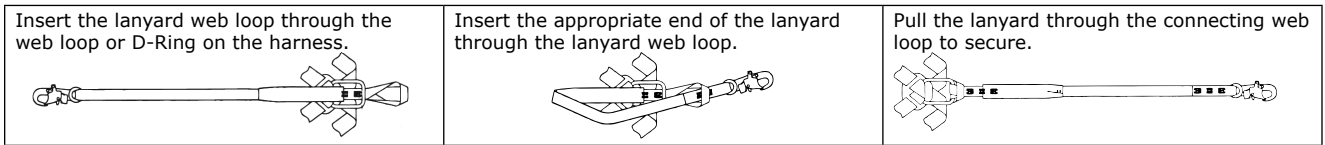

2.7 LANYARD PARKING ATTACHMENT: Figure 7 illustrates Lanyard Parking Attachments. The Lanyard Parking Attachment is for attaching the free end of a Lanyard or harness mounted Self-Retracting Device when not connected to an Anchorage Connection Point for purposes of fall protection. Lanyard Parking Attachments shall never be used as a Fall Protection Attachment Element.

Figure 7 – Lanyard Parking Attachments

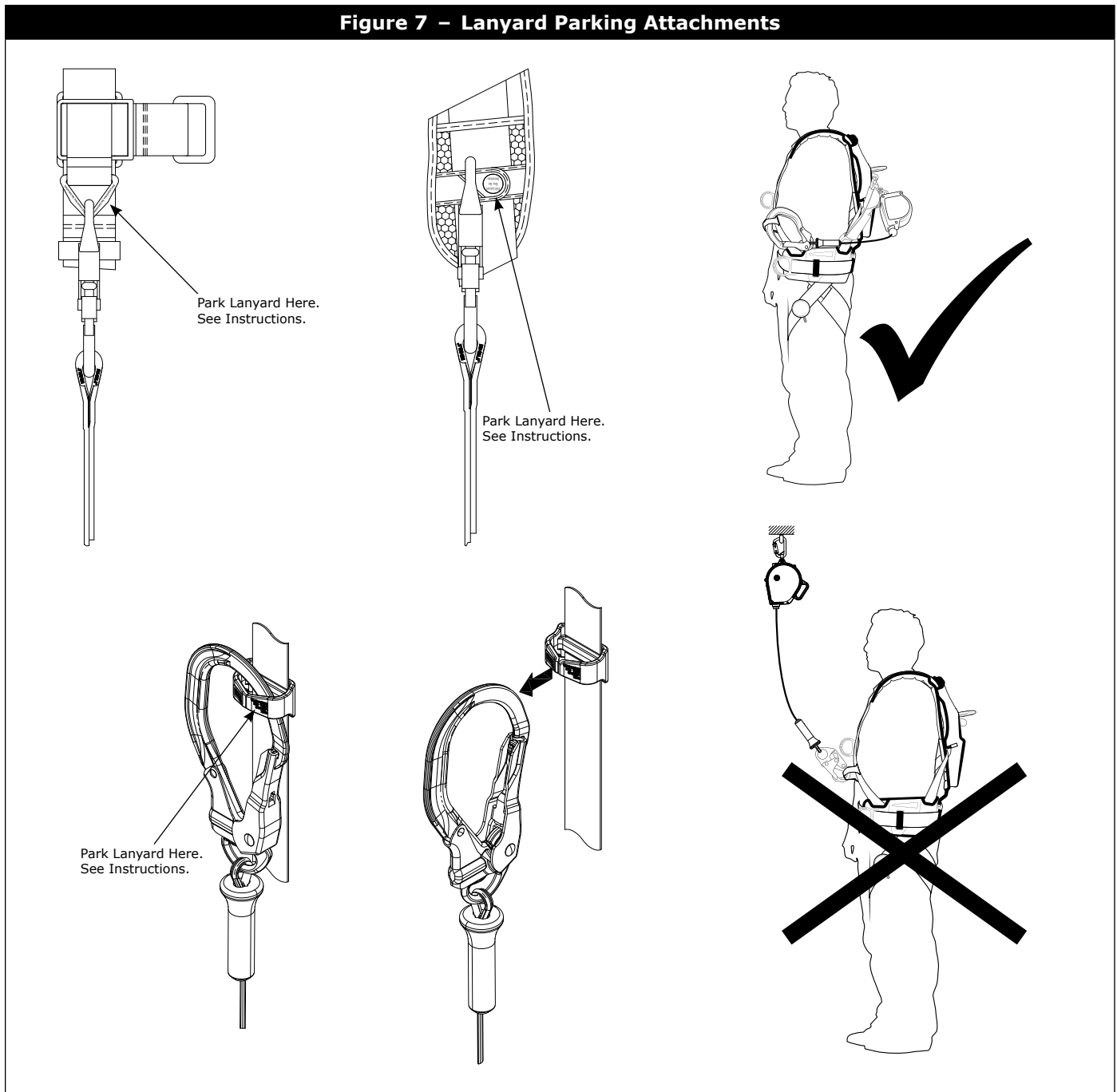

3.0 HARNESS USE

⚠ CAUTION: Do not alter or intentionally misuse this equipment. Consult Capital Safety when using this equipment in combination with components or subsystems other than those described in this manual. Some subsystem and component combinations may interfere with the operation of this equipment. Use caution when using this equipment around moving machinery, electrical and chemical hazards, and sharp edges.

⚠ WARNING: Consult your doctor if there is reason to doubt your fitness to safely absorb the shock from a fall arrest. Age and fitness seriously affect a worker's ability to withstand falls. Pregnant women or minors must not be exposed to fall hazards or fall arrest forces.

3.1 BEFORE EACH USE of this equipment inspect it according to the "Inspection and Maintenance Log" (Table 1).

3.2 PLAN your system before use. Consider all factors that will affect your safety during use of this equipment. The following list gives important points to consider when planning your system:



- **ANCHORAGE:** Select an anchorage that meets the requirements specified in "Limitations and Requirements".
- **SHARP EDGES:** Avoid working where system components may be in contact with, or abrade against, unprotected sharp edges.
- **AFTER A FALL:** Components which have been subjected to the forces of arresting a fall must be removed from service and destroyed.
- **RESCUE:** The employer must have a rescue plan when using this equipment. The employer must have the ability to perform a rescue quickly and safely.

3.3 BUCKLES: ExoFit Strata™ Full Body Harnesses are equipped with various buckles for fastening Leg Straps, Chest Straps, Body Belts, etc. See Figure 1 for the buckle types on your ExoFit Strata Harness. Figure 8 illustrates operation of each of the following buckles:

1. Tri-Lock Revolver™ Buckles:

- A. To fasten the Tri-Lock Revolver Buckle: Insert the Tab on the Revolver End in the Access Slot on the Receptor. Pull the Tab back in the slot until it clicks into locked position.
- B. To tighten the Web Strap, rotate the Revolver Ratchet Knobs away from your body. To loosen the Web Strap, pull out and rotate the Revolver Ratchet Knob toward your body while pulling the Web Strap out of the Revolver Spindle.
- C. To release the Tri-Lock Revolver Buckle: Squeeze the Lock Levers on each side of the Receptor. Slide the Tab forward and then pull it out of the Access Slot.

2. Duo-Lok™ Quick Connect Buckles:

- A. To fasten the Duo-Lok Quick Connect Buckle, insert the Tab into the Receptor until a click is heard.
- B. To adjust the attached Web Strap: Rotate the Webbing Lock to the Unlocked position . Pull the Web Strap forward or backward through the Buckle Slot to tighten or loosen. After adjustment, rotate the Webbing Lock to the Locked position .

⚠ IMPORTANT: The Webbing Lock does not lock or unlock engagement or disengagement of the buckle end. It only prevents or allows passage of the excess Web Strap through the Buckle Slot.

- C. To release the Duo-Lok Quick Connect Buckle: Squeeze the Lock Levers on each side of the Receptor. Pull the Tab out of the Receptor.

3. Tongue Buckles: Fasten and adjust Tongue Buckles by passing the Tongue through the Buckle Frame and inserting the Prong through the desired Grommet in the webbing.

3.4 ADJUSTMENTS: ExoFit Strata Harnesses are equipped with an adjustable LIFTech™ Weight Distribution System that redistributes harness weight from the wearer's shoulders to their hips. They also have a pair of Revolver™ Torso Adjusters for adjusting the Shoulder Straps. Figure 9 illustrates adjustment of the LIFTech Weight Distribution System and Revolver Torso Adjusters:

1. LIFTech™ Weight Distribution System: To adjust the LIFTech system:

- A. Unzip the Back Pad to expose the LIFTech Adjustment Bar.
- B. Grasp the Adjustment Bar, depress the Adjustment Button, and slide the Adjustment Bar up or down until the Adjustment Button aligns in the desired hole. Maximum gap between the Shoulder Pads and wearer's shoulders should not exceed 1/4 in. (0.6 cm).
- C. Zip the Back Pad closed.

2. Revolver™ Torso Adjusters: To adjust the Shoulder Straps with the Revolver Torso Adjusters:

- A. Rotate the Revolver Ratchet Knobs as illustrated to tighten the Shoulder Straps.
- B. Pull out and rotate the Revolver Ratchet Knobs as illustrated to loosen the Shoulder Straps.

Figure 8 – Buckles

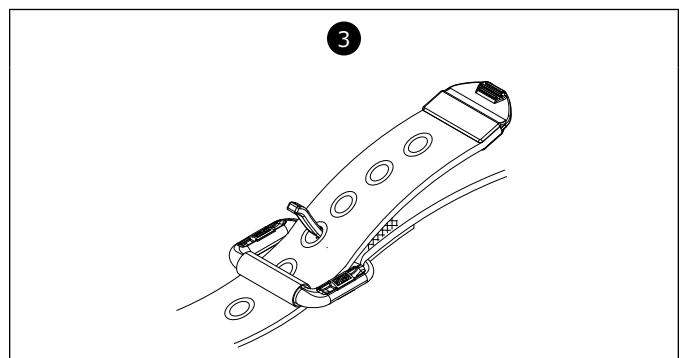
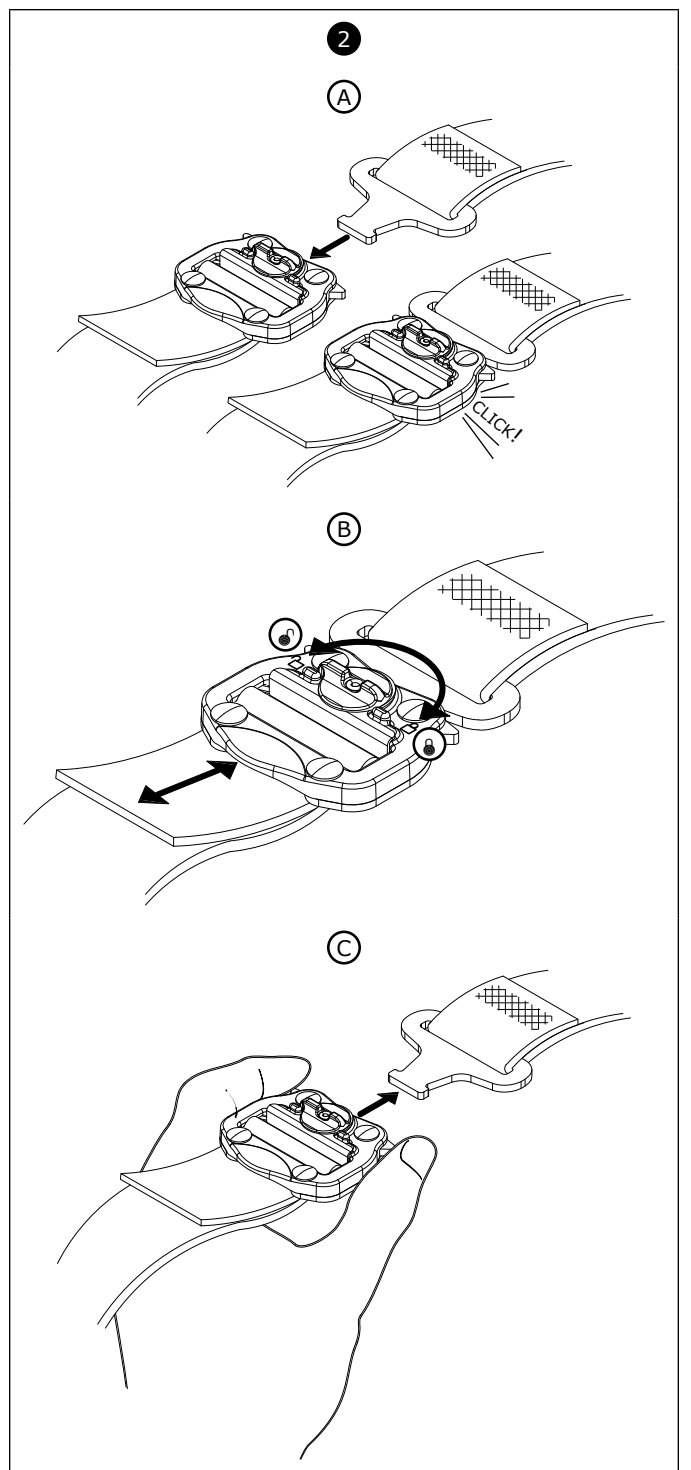
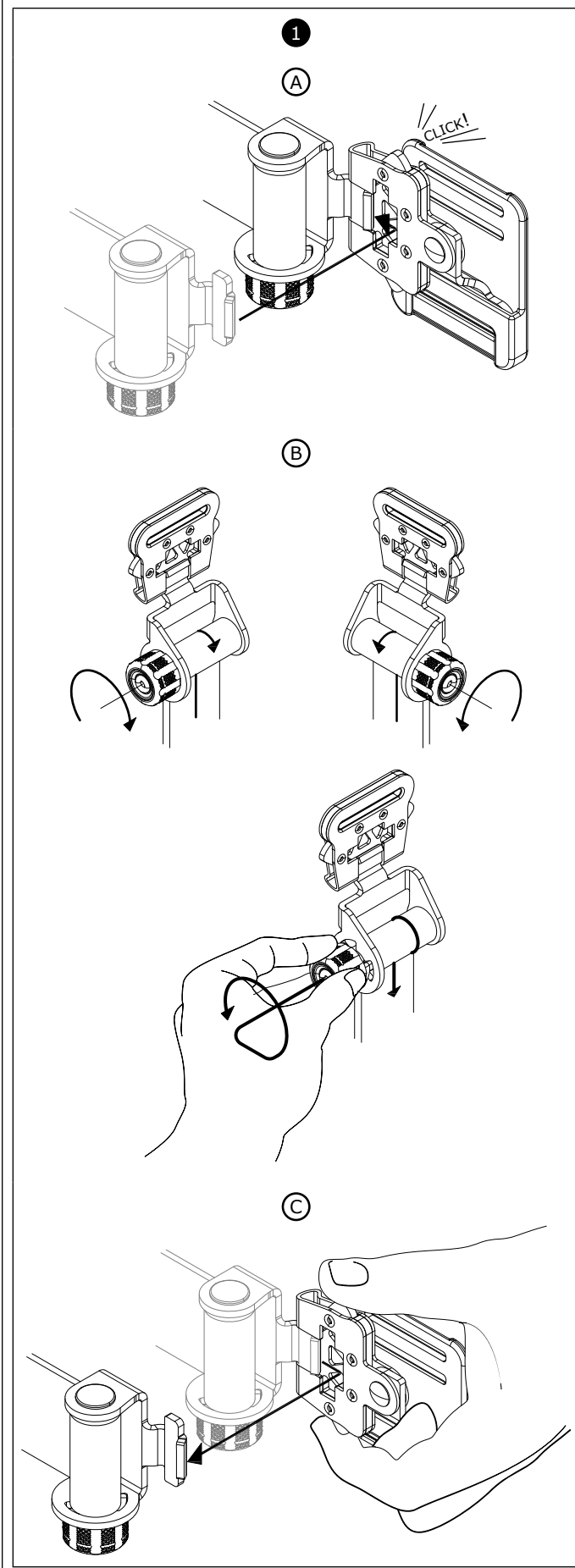
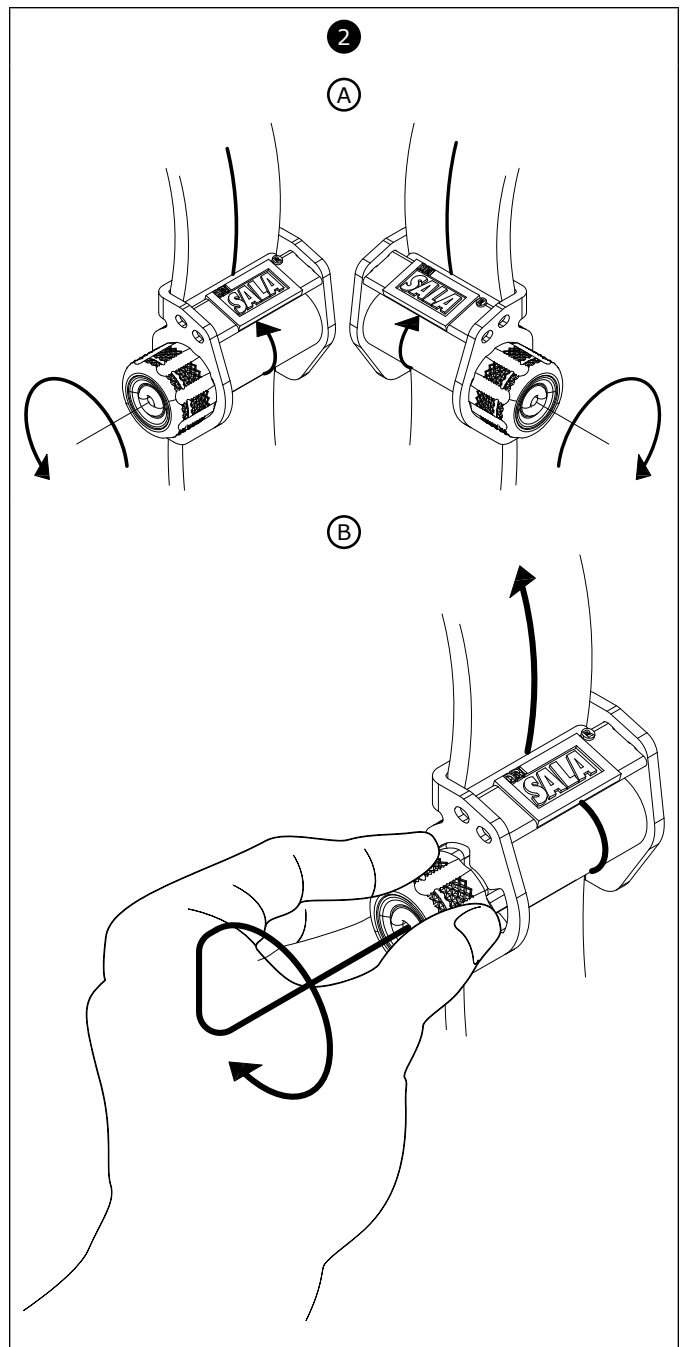
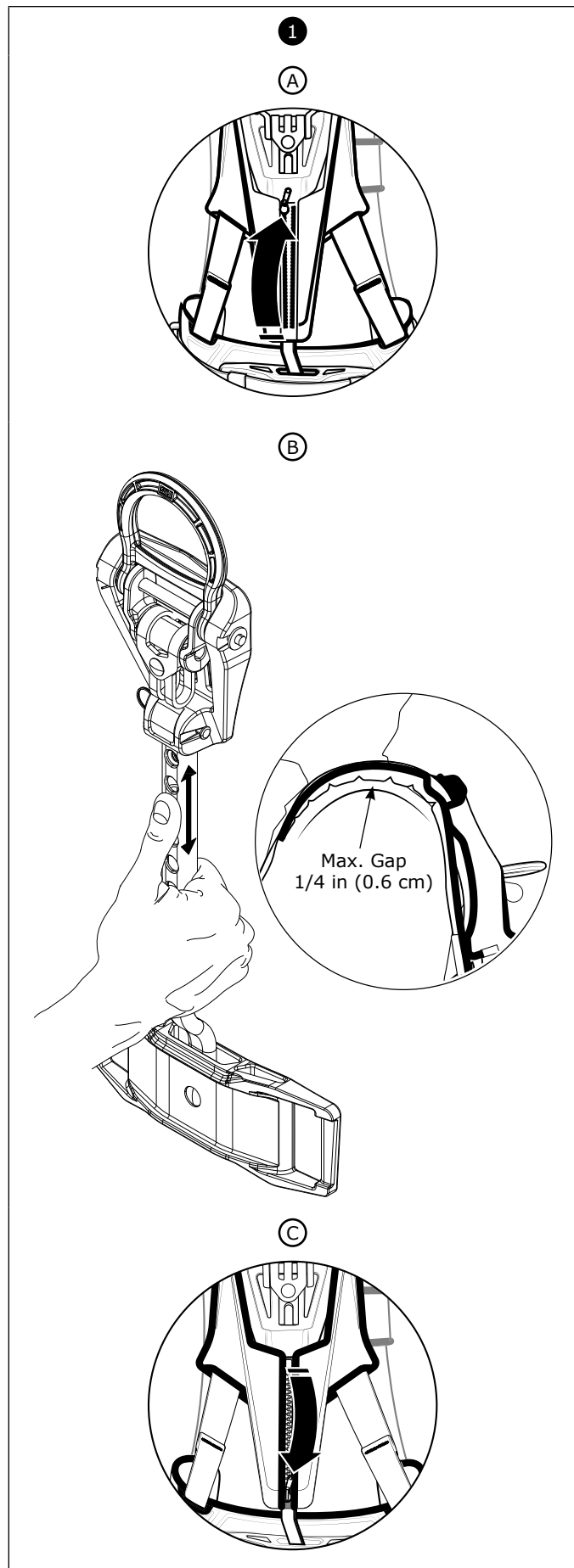

Figure 9 – Adjustments



3.5 EASY-LINK™ ATTACHMENTS: ExoFit Strata Full Body Harnesses are equipped with an Easy-Link™ System that integrates the Dorsal D-Ring with attachment elements for Harness-Mounted Self-Retracting Devices (SRDs). Figure 10 illustrates attachment of various DBI-SALA and Protecta Self-Retracting Devices. Other manufacturers' SRDs can also be mounted on the ExoFit Strata Harness in similar fashion. See the SRD manufacturer's instructions for requirements and installation instructions specific to the SRD.

① **IMPORTANT:** Contact DBI-SALA with any questions or concerns regarding compatibility of your SRD with the Easy-Link System.

Figure 10 – Easy Link™ Attachments

DBI-SALA Nano-Lok™ Edge SRDs

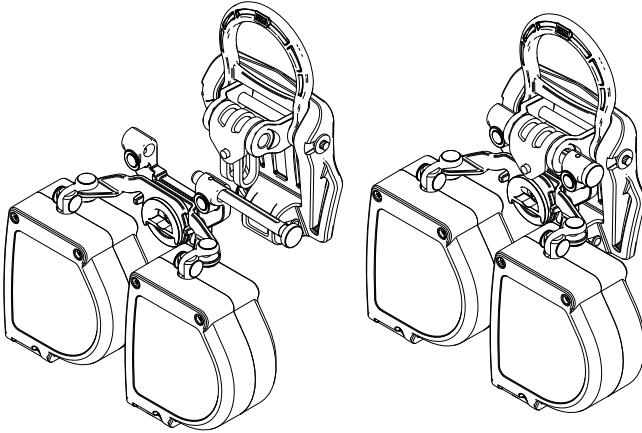

DBI-SALA Nano-Lok™ SRDs (Twin)

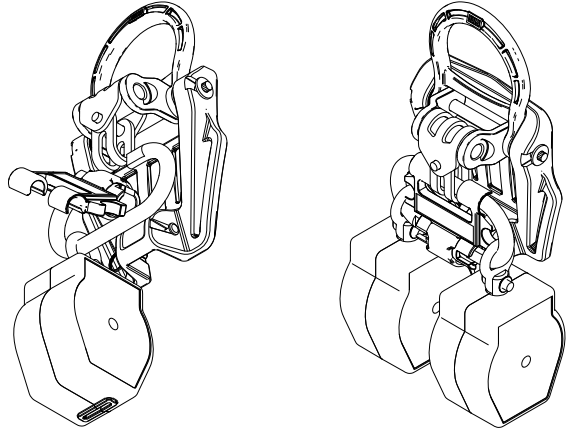

DBI-SALA Nano-Lok™ SRD (Single)

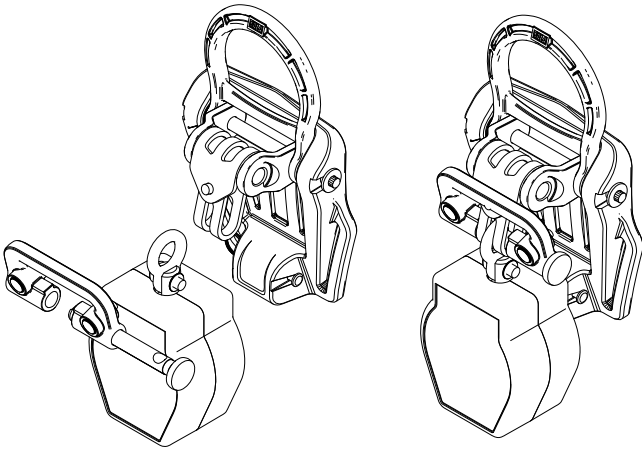

Protecta Rebel™ SRDs (Twin)

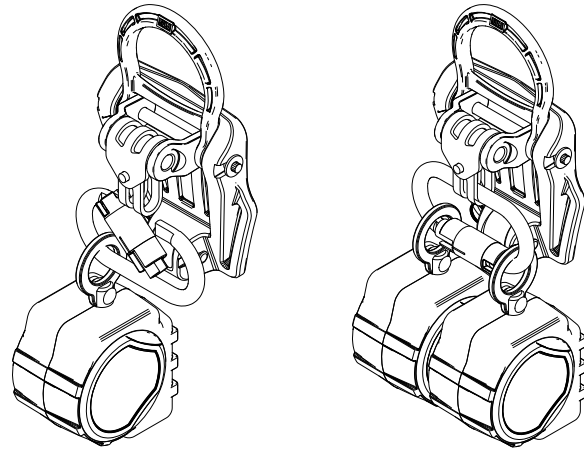

DBI-SALA Talon™ SRD (Twin)

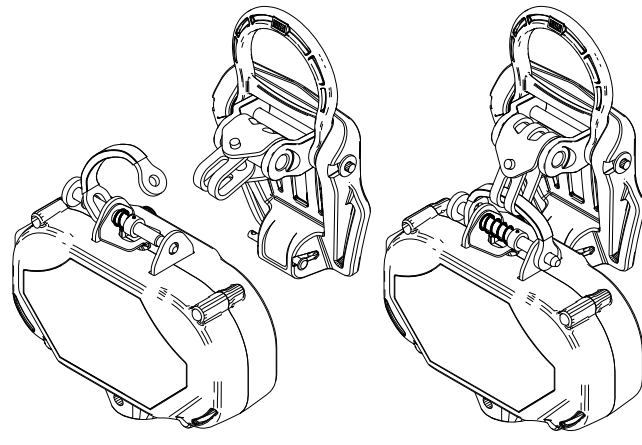

- 3.6 STORE-AWAY STERNAL D-RING ADJUSTMENT:** Some ExoFit Strata Harness models are equipped with a Store-Away Sternal D-Ring (see Figure 11). The Store-Away D-Ring folds flat against the Chest Strap when not in use, folds out perpendicular to the Chest Strap when in use. It can slide from side to side along the Chest Strap for proper positioning.

① **IMPORTANT:** All Single Point Attachment Elements (Sternal D-Ring, Dorsal D-Ring, etc.) shall be located laterally within 2 in. (51 mm) of the vertical centerline of the Full Body Harness.

Figure 11 – Store-Away Sternal D-Ring

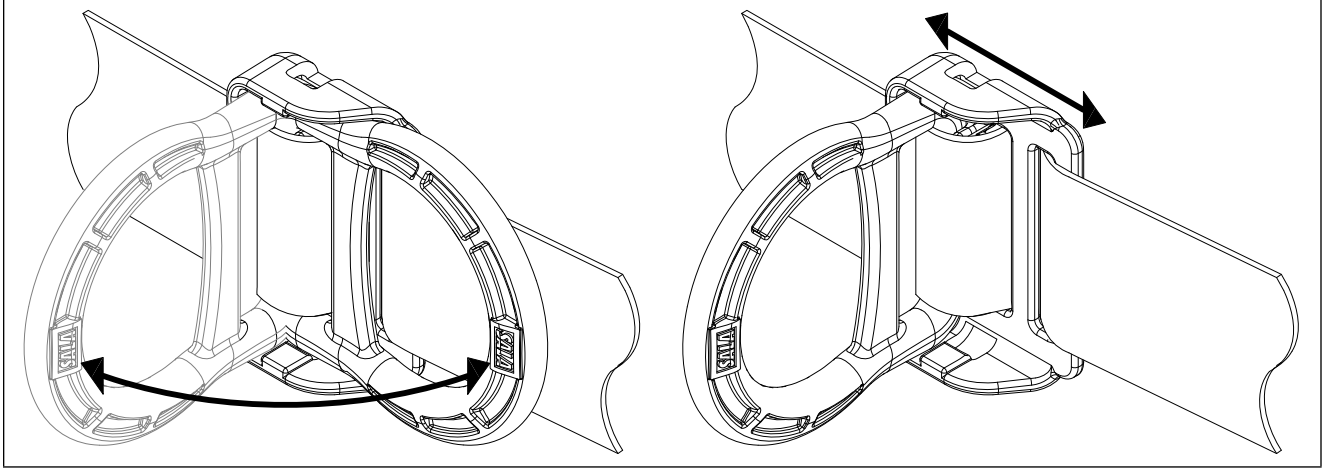

- 3.7 TOOL BAG ATTACHMENT:** Figure 12 illustrates attachment of a Tool Bag on the ExoFit Strata Harness. To mount the Tool Bag on the harness, thread the Waist Belt on the harness through the Belt Loops on the Hip/Lumbar Pad and Tool Bag.

① **IMPORTANT:** Combined weight of the harness wearer, clothing, tools, etc. shall not exceed the 'Capacity' stated in "Section 1.4 Limitations".

Figure 12 – Tool Bag Attachment

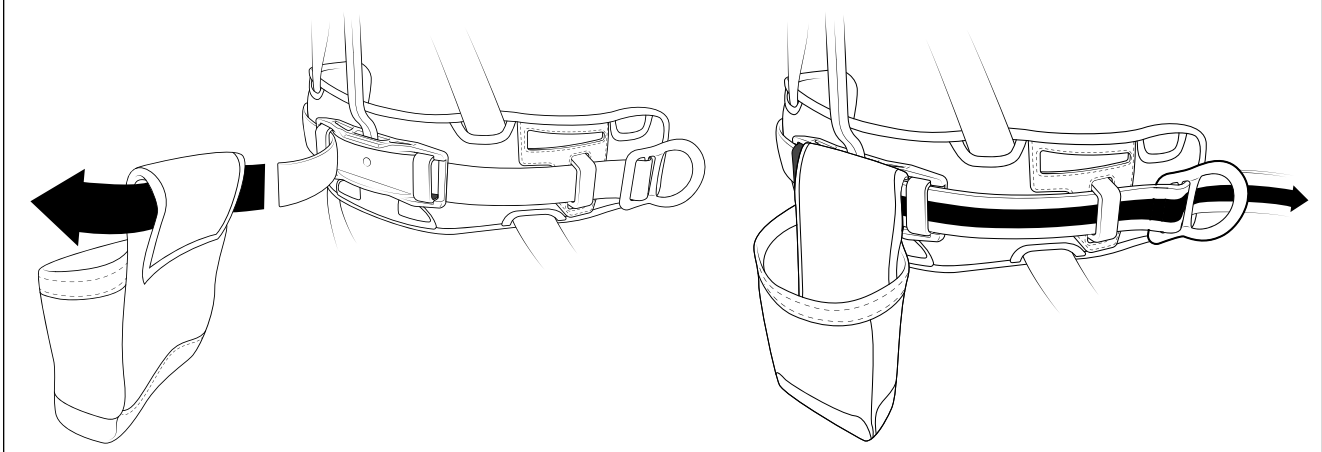

- 3.8 DONNING AND FITTING THE EXOFIT STRATA FULL BODY HARNESS:** Figure 13 illustrates donning and fitting of the ExoFit Strata Full Body Harness. Prior to each use, inspect the harness per the checklist on the "Inspection and Maintenance Log (Table 1)". To don and fit the harness:

NOTE: Procedures for buckling and adjusting the straps on the ExoFit Strata Harness will vary with the harness model. See Sections 3.3 thru 3.4 and Figures 8 thru 9 for details.

1. Lift up and hold the harness by the back Dorsal D-Ring on the Easy-Link System. Ensure the straps are not twisted.
2. Grasp the Shoulder Straps and slip the harness onto one arm. The Dorsal D-Ring will be located on your back side. Ensure that the straps are not tangled and hang freely. Slip your free arm into the harness and position the Shoulder Straps on top of your shoulders. The Chest Strap and Chest Buckle will be positioned on the front side when worn properly.

3. Reach between your legs and grasp the Leg Strap on your right side. Bring the strap up between your legs, buckle to the mating receptor on your right hip, and adjust the Leg Strap for a snug comfortable fit (see Section 3.3 for buckle operation). When properly adjusted, tuck the loose end of the Leg Strap under the Strap Keeper. Repeat this process to buckle and adjust the left Leg Strap.
4. Adjust and buckle the Tongue Buckle Waist Belt (see Section 3.3 for Tongue Buckle operation).
5. Buckle and adjust the Chest Strap (see Section 3.3 for buckle operation). The Chest Strap should be 6 in. (15 cm) down from the top of your shoulders. When properly adjusted, tuck the loose end of the Chest Strap under the Strap Keeper.
6. Adjust the Shoulder Straps for a Snug Fit with the Revolver Torso Adjusters (see Section 3.4 for Torso Adjuster operation). Left and right sides of Shoulder Straps should be adjusted to the same length and the Chest Strap should be centered on your lower chest, 6 in. (15 cm) down from the shoulders. The back Dorsal D-Ring should be centered between your Shoulder Blades. The front Sternal D-Ring, if present, should be located laterally within 2 in. (51 mm) of the vertical centerline of the harness (see Section 3.6 for Store-Away D-Ring adjustment).
7. If necessary, have someone adjust the LIFTech Weight Distribution System so harness weight is distributed from your shoulders to your hips (see Section 3.4. for LIFTech instructions).

Figure 13 – Donning and Fitting the ExoFit Strata Full Body Harness

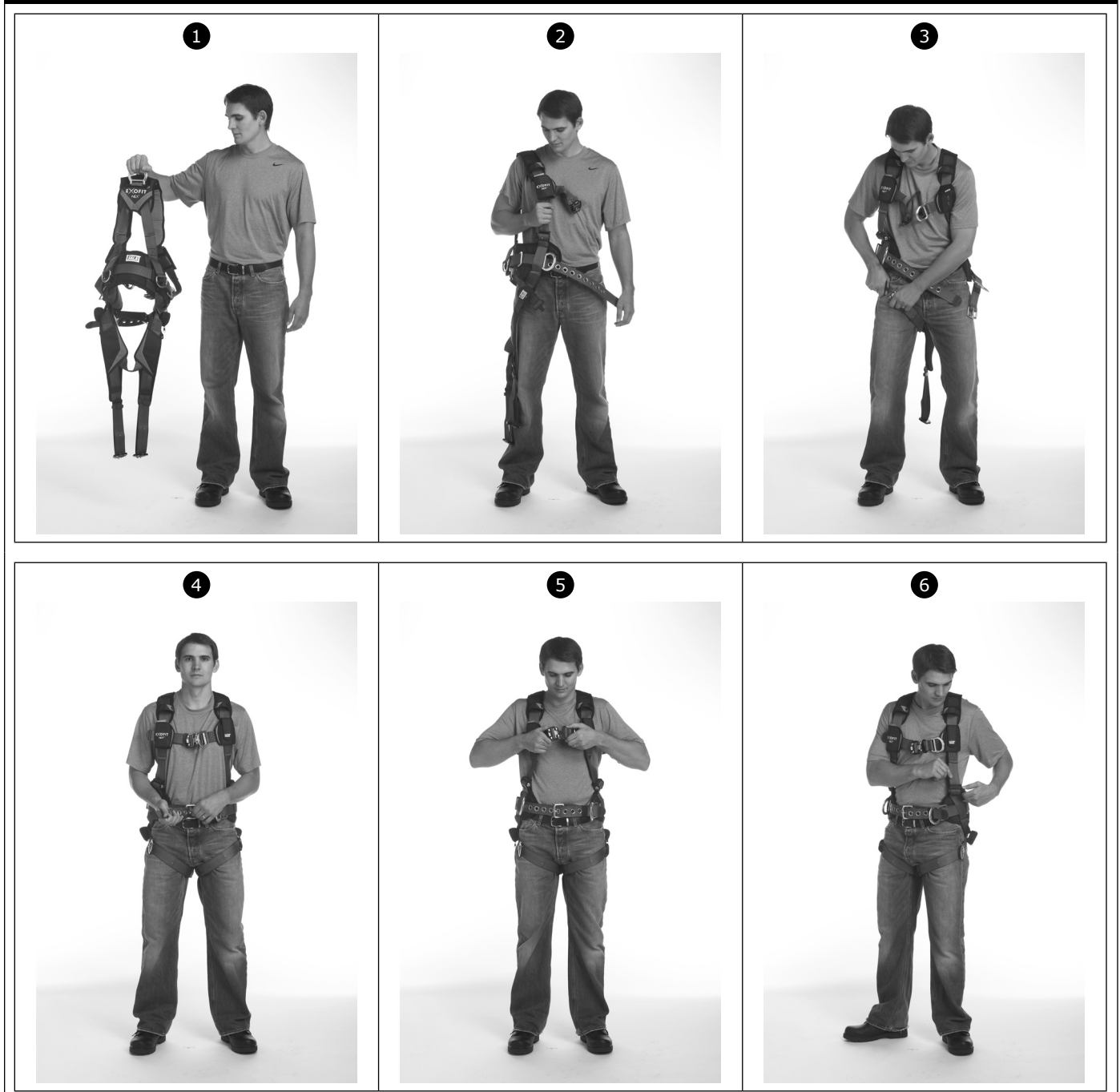

3.9 USE OF FALL ARREST D-RING OR ATTACHMENT ELEMENT: For Fall Arrest applications connect to the Dorsal D-Ring or attachment element on your back, between your shoulder blades. Side D-Rings, if present, are for Positioning or Restraint applications only. Shoulder D-Rings are for Rescue or Retrieval applications only. The front Sternal D-Ring is for Ladder Climbing or Positioning. D-Rings on a Suspension Seat are for Suspension or Positioning applications only. (See Section 1.1.).

3.10 MAKING CONNECTIONS: When using a hook to connect to an anchorage or when coupling components of the system together, ensure roll-out cannot occur. Roll-out occurs when interference between the hook and mating connector causes the hook gate to unintentionally open and release. Self-locking snap hooks and carabiners should be used to reduce the possibility of roll-out. Do not use hooks or connectors that will not completely close over the attachment object. See subsystem manufacturer’s instructions for more information on making connections.

3.11 CONNECTING SYSTEM COMPONENTS: After fitting the ExoFit Strata Harness the user may then connect to other system components. Follow the guidelines in Section 2 and the manufacturer’s instructions included with the component.

3.12 SUSPENSION TRAUMA STRAP: The ExoFit Strata Full Body Harness is equipped with Suspension Trauma Straps (Figure 14) to help prolong allowable suspension time in the event of a fall from height. They should only be used in situations where a fall has occurred or for training. To use the Suspension Trauma Straps:

1. Unzip the Trauma Strap Pouch on each hip of the harness and deploy the Suspension Straps (Figure 14A).
2. Raise the ends of the straps to access the hook and loops. Insert the hook into the loop that provides the desired strap length.
3. Lower the Suspension Strap and step onto the strap to alleviate pressure of the harness leg straps on the legs (Figure 14B). Adjust the hook/loop combination for optimal comfort.

⚠ WARNING: Maintain an upright position following suspension. Do not lay down. Seek medical attention following a suspension.

4.0 INSPECTION

⚠ WARNING: If the full body harness has been subjected to fall arrest or impact forces it must be immediately removed from service and destroyed.

4.1 I-SAFE™ RFID TAG: The i-Safe™ RFID tag on the ExoFit Strata™ Harness (see Figure 15) can be used in conjunction with the i-Safe handheld reading device and the web based portal to simplify inspection and inventory control and provide records for your fall protection equipment.

4.2 INSPECTION FREQUENCY: The ExoFit Strata Full Body Harness must be inspected at the intervals defined in Section 2.2. Inspection procedures are described on the "Inspection and Maintenance Log" (Table 1).

4.3 DEFECTS: If inspection reveals a defective condition, remove unit from service immediately and destroy.

4.4 PRODUCT LIFE: The functional life of ExoFit Strata Harnesses is determined by work conditions and maintenance. As long as the product passes inspection criteria, it may remain in service.

① NOTE: Only DBI-SALA or parties authorized in writing may make repairs to this equipment.

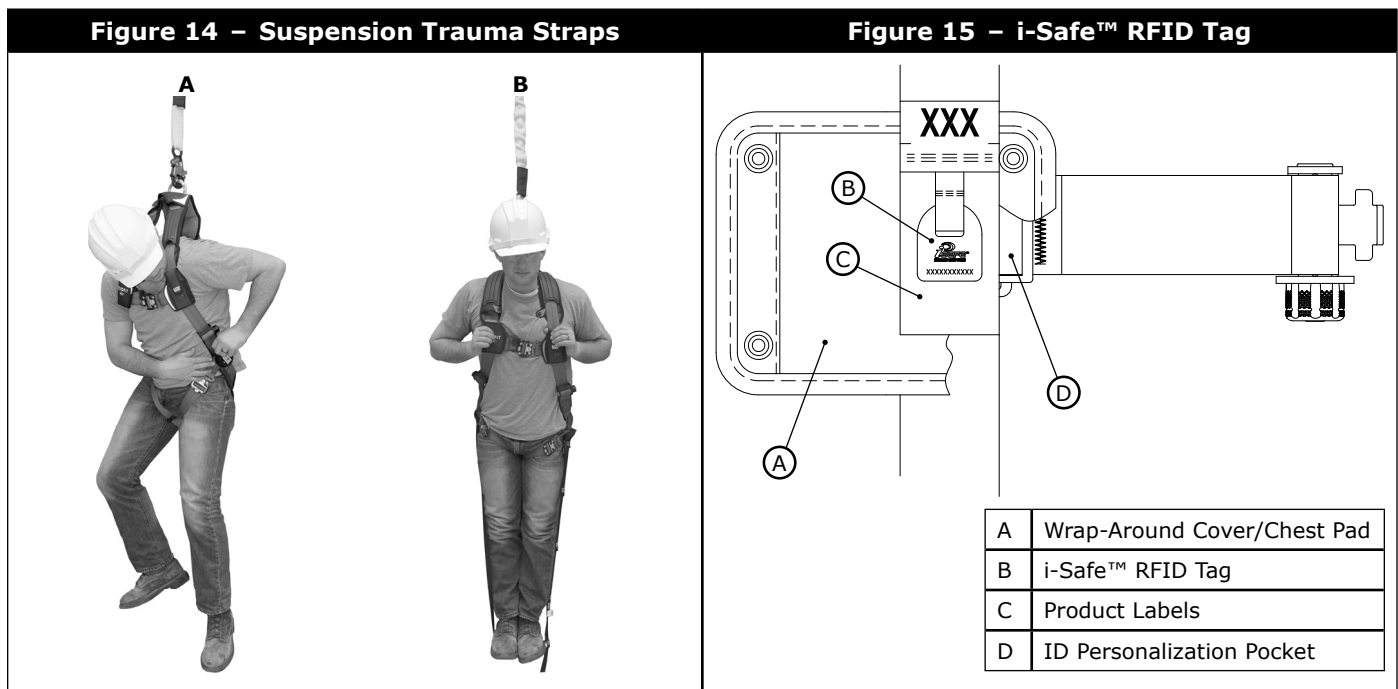

5.0 MAINTENANCE, SERVICING, STORAGE

5.1 CLEANING INSTRUCTIONS: Clean the ExoFit Strata™ Full Body Harness as follows:

1. Spot clean the harness with water and a mild soap solution.

ⓘ **IMPORTANT:** Use a bleach-free detergent when washing the harness and pads. Fabric softener or dryer sheets **SHOULD NOT** be used when laundering and drying the harness and pads.

2. Water temperature for wash and rinse must not exceed 160° F (70° C).
3. The harness and pads may be air dried or tumble dried on low heat not exceeding 200° F (90° C).

ⓘ **NOTE:** More information on cleaning is available from DBI-SALA. If you have questions concerning the condition of your harness, or have any doubt about putting it into service, contact DBI-SALA.

5.2 AUTHORIZED SERVICE: Additional maintenance and servicing procedures must be completed by a factory authorized service center. Authorization must be in writing. Do not attempt to disassemble the unit.

5.3 STORAGE AND TRANSPORT: Store and transport the ExoFit Strata Full Body Harness in a cool, dry, clean environment out of direct sunlight. Avoid areas where chemical vapors may exist. Thoroughly inspect the harness after extended storage.

6.0 LABELING:

Figure 16 illustrates product labels and their location on the ExoFit Strata™ Full Body Harness. All labeling must be present and fully legible.

Figure 16 – Labeling

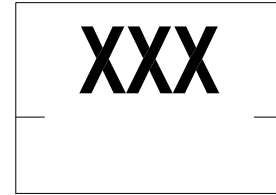
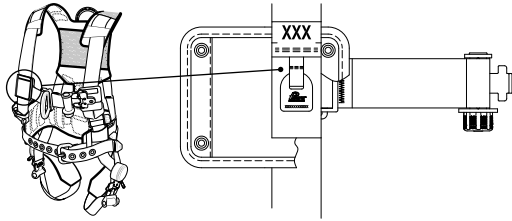

9503437 Rev. C

WARNING MANUFACTURER'S INSTRUCTIONS MUST BE READ AND UNDERSTOOD PRIOR TO USE. INSTRUCTIONS SUPPLIED WITH THIS PRODUCT AT TIME OF SHIPMENT MUST BE FOLLOWED. FAILURE TO DO SO COULD RESULT IN SERIOUS INJURY OR DEATH. CONTACT CAPITAL SAFETY IF INSTRUCTION SHEET IS NEEDED. INSPECT BEFORE EACH USE. REMOVE FROM SERVICE AFTER FALL ARREST. REMOVE FROM SERVICE IF WEAR DAMAGE IS PRESENT DURING INSPECTION. MAKE ONLY COMPATIBLE CONNECTIONS. DO NOT ALTER OR REPAIR HARNESS.

AVERTISSEMENTS LES INSTRUCTIONS DU FABRIQUANT DOIVENT ETRE LUES ET COMPRISES PREALABLEMENT A L'UTILISATION. LES INSTRUCTIONS FOURNIES AVEC CE PRODUIT AU MOMENT DE L'EXPEDITION DOIVENT ETRE SUIVIES. NEGLIGER CES RECOMMANDATIONS PEUT ENTRAINER DES BLESSURES GRAVES, VOIRE MORTELLES. CONTACTER CAPITAL SASETY EN CAS DE BESOIN DE NOTICE. INSPECTER AVANT CHAQUE UTILISATION. METTRE HORS SERVICE APRES L'ARRÊT D'UNE CHUTE. METTRE HORS SERVICE SI L'INSPECTION REVELE DES DOMMAGES DUS A L'USURE. EFFECTUER SEULEMENT DES FIXATIONS COMPATIBLES. NE PAS MODIFIER OU REPARER LE HARNAIS.

DBI
SALA®

BODY HARNESS/Harnais de sécurité
POLYESTER WEB/Sangle: polyester
SIZE/GRANDEUR: SEE LABEL/
DO NOT REMOVE THIS LABEL/
Ne pas enlever cette étiquette

www.capitalsafety.com
Capital Safety
+1-800-328-6146

HARNESS CLASSIFICATION/
Classe de Harnais

CSA STANDARD Z259.10

USER IDENTIFICATION/
IDENTIFICATION DE L'UTILISATEUR
MARK LABEL WITH PERMANENT
MARKER/MARQUER L'ÉTIQUETTE AVEC
UN MARQUEUR PERMANENT.

9503320 REV C

1) FALL ARREST, CLASS A, AND RESCUE/ARRÊT DES CHUTES ET SAUVEPAGE CLASSE A (ANSI Z359.1 & ANSI Z359.4)
2) SUSPENSION OR CONTROLLED DESCENT/CLASSE D/CLASSE D
3) LIMITED ACCESS/RESCUE/ACCES LIMITE/SAUVEPAGE CLASSE E/CLASSE E (ANSI Z359.4)
4) WORK POSITIONING/MANTENIR EN POSITION DE TRAVAIL CLASSE P/CLASSE P (ANSI Z359.3)

*) LADDER ACCESS/ACCES AUX ÉCHELLES CLASSE L/CLASSE L (ANSI Z359.1)
*) FOR SYSTEMS MEETING/POUR LES SYSTEMES SOUS LA NORME ANSI Z359.1 – MAY BE USED FOR FALL ARREST (2 FT. MAXIMUM FREE FALL)/ PEUT UTILISER POUR L'ARRÊT DES CHUTES (2 FT. (0.6m) DE CHUTE LIBRE MAXIMUM). CE OR AZ/NECES – MAY BE USED FOR FALL ARREST./ PEUT ETRE UTILISE POUR L'ARRÊT DES CHUTES

SEE INSTRUCTIONS FOR MORE DETAILS/VOIR LES INSTRUCTIONS POUR PLUS DÉTAILS

9502095 Rev. A

INSPECTION LOG
RELEVÉ D'INSPECTION

SERIAL NO./NUMÉRO DE SÉRIE:
SEE RFID TAG IN CLEAR POUCH
VOIR L'ÉTIQUETTE DE RFID
DANS LA POCHE TRANSPARENTE

DATE	INITIAL					

DO NOT REMOVE THIS LABEL
NE PAS ENLEVER CETTE ÉTIQUETTE

MFRD/LOT/FABR. LOT:
(YR/MO)/(AA/MM)

MODEL NO./MODÈLE

Table 1 – Inspection and Maintenance Log

Serial Number(s):	Date Purchased:
Model Number:	Date of First Use:

Inspection Date:	Inspected By:
-------------------------	----------------------

Component:	Inspection: <i>(See Section 2.2 for Inspection Frequency)</i>	User	Competent Person
Harness Hardware (Diagram 1)	Inspect harness hardware including buckles (1), adjusters (2), D-rings (3), Easy-Link (4), LIFTech (5), loop keepers (6), lanyard parking (7), etc. These items must not be damaged, broken, or distorted, and must be free of sharp edges, burrs, cracks, worn parts, or corrosion. PVC coated hardware must be free of cuts, rips, tears, holes, etc. in the coating to ensure non-conductivity. Ensure buckles and adjusters work smoothly.	<input type="checkbox"/>	<input type="checkbox"/>
Webbing & Stitching (Diagram 2)	Inspect webbing; material must be free of frayed, cut, or broken fibers. Check for tears, abrasions, mold, burns, or discoloration. Inspect stitching; Check for pulled or cut stitches. Broken stitches may be an indication that the harness has been impact loaded and must be removed from service.	<input type="checkbox"/>	<input type="checkbox"/>
Stitched Impact Indicators (Diagram 3)	The Stitched Impact Indicators are sections of webbing lapped back on themselves and secured with a specific stitch pattern. The stitch pattern is designed to release when the harness arrests a fall or is exposed to equivalent force. If an Impact Indicator has been activated (indicated), the harness must be removed from service and destroyed.	<input type="checkbox"/>	<input type="checkbox"/>
Labels	All labels should be present and fully legible. See Figure 16.	<input type="checkbox"/>	<input type="checkbox"/>
System & Subsystem Components	Inspect each system component or subsystem according to the manufacturer’s instructions.	<input type="checkbox"/>	<input type="checkbox"/>

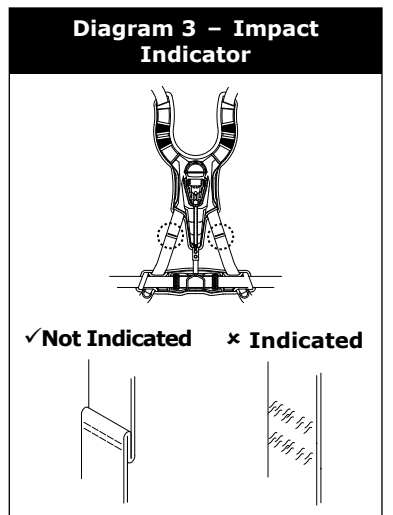
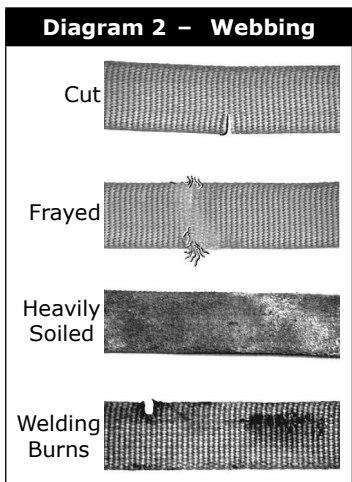
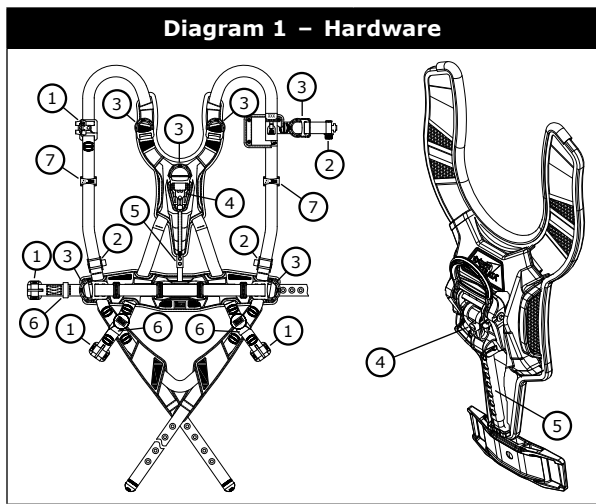

Corrective Action/Maintenance:	Approved By:
	Date:
Corrective Action/Maintenance:	Approved By:
	Date:
Corrective Action/Maintenance:	Approved By:
	Date:
Corrective Action/Maintenance:	Approved By:
	Date:
Corrective Action/Maintenance:	Approved By:
	Date:
Corrective Action/Maintenance:	Approved By:
	Date:
Corrective Action/Maintenance:	Approved By:
	Date:
Corrective Action/Maintenance:	Approved By:
	Date:

LIMITED LIFETIME WARRANTY

Warranty to End User: D B Industries, LLC dba CAPITAL SAFETY USA ("CAPITAL SAFETY") warrants to the original end user ("End User") that its products are free from defects in materials and workmanship under normal use and service. This warranty extends for the lifetime of the product from the date the product is purchased by the End User, in new and unused condition, from a CAPITAL SAFETY authorized distributor. CAPITAL SAFETY'S entire liability to End User and End User's exclusive remedy under this warranty is limited to the repair or replacement in kind of any defective product within its lifetime (as CAPITAL SAFETY in its sole discretion determines and deems appropriate). No oral or written information or advice given by CAPITAL SAFETY, its distributors, directors, officers, agents or employees shall create any different or additional warranties or in any way increase the scope of this warranty. CAPITAL SAFETY will not accept liability for defects that are the result of product abuse, misuse, alteration or modification, or for defects that are due to a failure to install, maintain, or use the product in accordance with the manufacturer's instructions.

CAPITAL SAFETY'S WARRANTY APPLIES ONLY TO THE END USER. THIS WARRANTY IS THE ONLY WARRANTY APPLICABLE TO OUR PRODUCTS AND IS IN LIEU OF ALL OTHER WARRANTIES AND LIABILITIES, EXPRESSED OR IMPLIED. CAPITAL SAFETY EXPRESSLY EXCLUDES AND DISCLAIMS ANY IMPLIED WARRANTIES OF MERCHANTABILITY OR FITNESS FOR A PARTICULAR PURPOSE, AND SHALL NOT BE LIABLE FOR INCIDENTAL, PUNITIVE OR CONSEQUENTIAL DAMAGES OF ANY NATURE, INCLUDING WITHOUT LIMITATION, LOST PROFITS, REVENUES, OR PRODUCTIVITY, OR FOR BODILY INJURY OR DEATH OR LOSS OR DAMAGE TO PROPERTY, UNDER ANY THEORY OF LIABILITY, INCLUDING WITHOUT LIMITATION, CONTRACT, WARRANTY, STRICT LIABILITY, TORT (INCLUDING NEGLIGENCE) OR OTHER LEGAL OR EQUITABLE THEORY.



Global Leader in Fall Protection

USA

3833 SALA Way
Red Wing, MN 55066-5005
Toll Free: 800.328.6146
Phone: 651.388.8282
Fax: 651.388.5065
solutions@capitalsafety.com

Brazil

Rua Anne Frank, 2621
Boqueirão Curitiba PR
81650-020
Brazil
Phone: 0800-942-2300
brasil@capitalsafety.com

Mexico

Calle Norte 35, 895-E
Col. Industrial Vallejo
C.P. 02300 Azcapotzalco
Mexico D.F.
Phone: (55) 57194820
mexico@capitalsafety.com

Colombia

Compañía Latinoamericana de Seguridad S.A.S.
Carrera 106 #15-25 Interior 105 Manzana 15
Zona Franca - Bogotá, Colombia
Phone: 57 1 6014777
servicioalcliente@capitalsafety.com

Canada

260 Export Boulevard
Mississauga, ON L5S 1Y9
Phone: 905.795.9333
Toll-Free: 800.387.7484
Fax: 888.387.7484
info.ca@capitalsafety.com

EMEA (Europe, Middle East, Africa)

EMEA Headquarters:
5a Merse Road
North Moons Moat
Redditch, Worcestershire
B98 9HL UK
Phone: + 44 (0)1527 548 000
Fax: + 44 (0)1527 591 000
csgne@capitalsafety.com

France:

Le Broc Center
Z.I. 1re Avenue - BP15
06511 Carros Le Broc Cedex
France
Phone: + 33 04 97 10 00 10
Fax: + 33 04 93 08 79 70
information@capitalsafety.com

Australia & New Zealand

95 Derby Street
Silverwater
Sydney NSW 2128
Australia
Phone: +(61) 2 8753 7600
Toll-Free : 1800 245 002 (AUS)
Toll-Free : 0800 212 505 (NZ)
Fax: +(61) 2 8753 7603
sales@capitalsafety.com.au

Asia

Singapore:
69, Ubi Road 1, #05-20
Oxley Bizhub
Singapore 408731
Phone: +65 - 65587758
Fax: +65 - 65587058
inquiry@capitalsafety.com

Shanghai:

Rm 1406, China Venturetech Plaza
819 Nan Jing Xi Rd,
Shanghai 200041, P R China
Phone: +86 21 62539050
Fax: +86 21 62539060
inquiry@capitalsafety.cn

www.capitalsafety.com

