

Mohamed Fahmy Raslan\*

## **BENEFICIATION OF URANIUM-RICH FLUORITE FROM EL - MISSIKAT MINERALIZED GRANITE, CENTRAL EASTERN DESERT, EGYPT**

*Received June 5, 2008; reviewed; accepted July 31, 2008*

In a previous study, the occurrence and mineralogy of unique highly radioactive fluorite-rich granites from El-Missikat uranium occurrence was discussed. The uranium content of the bulk composite sample collected from the studied fluorite - bearing granites equal 1950 ppm. The presence of uranium element in the core of fluorite is quite evident. The fluorite crystals are mainly responsible for the radioactivity in the granitic samples. Microscopic examination for the accessory heavy minerals revealed that radioactive fluorite represents about 20% by weight of the original rock sample. Also, radioactive fluorite represents about 90% of the total accessory heavy minerals in addition to iron oxides and mica (fluoro-phlogopite). Physical upgrading of radioactive fluorite was carried out using gravitative and magnetic separation techniques. Under optimum conditions it was possible to attain a good concentrate with an acceptable recovery. Accordingly, the final concentrate contains up to 1.0274% U with a final recovery of 79.29% in a weight of 15.05% out of the original sample assays 0.1950% U.

*key words: uranium, radioactive fluorite, heavy minerals, granite, upgrading*

### **INTRODUCTION**

El-Missikat granite pluton is located in the central part of the Eastern Desert at about 85 km midway between Safaga on the Red Sea Coast and Qena in the Nile Vally (Fig. 1). Uranium mineralization (mainly uranophane) is associated with jasperoid veins which occur within shear zones (Bakhit 1978; Abu Dief 1985; Hussein et al., 1986 and Abu Dief et al., 1997). However, unlike all the mineralized silicious veins in El-Missikat, visible deep blue to violet fluorite crystals occur as disseminations in

---

\* Nuclear Materials Authority, Cairo, Egypt

the highly sheared granite of El-Missikat granite pluton with very strong radioactivity but without visible secondary uranium mineralization (Fig. 2a). The presence of uranium element in the core of fluorite is quite evident. Electron Microprobe analyses for El-Missikat radioactive fluorite revealed that the uranium content ranges from 0.10 to 0.22 % with an average of 0.06 % and thorium ranges from 0.25 to 0.75 % with an average of 0.25 %, Raslan (In preparation). Microscopic examination for the accessory heavy minerals revealed that radioactive fluorite represents about 20% by weight of the original rock sample.

The aim of this study is to investigate the potentiality of physical upgrading of the radioactive fluorite-rich granite using mainly gravitative and magnetic separation techniques.

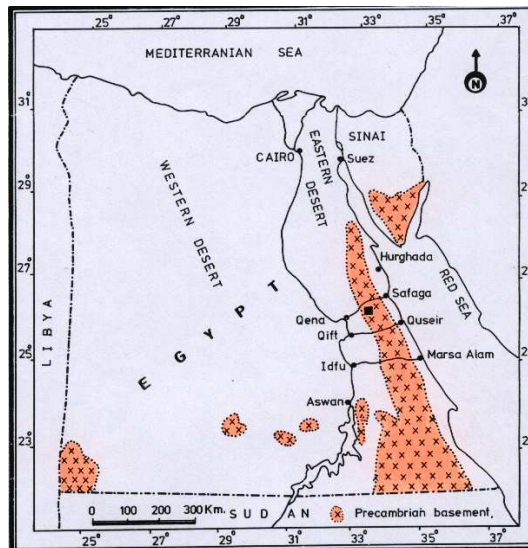

Fig. 1. Location map of El-Missikat uranium occurrence

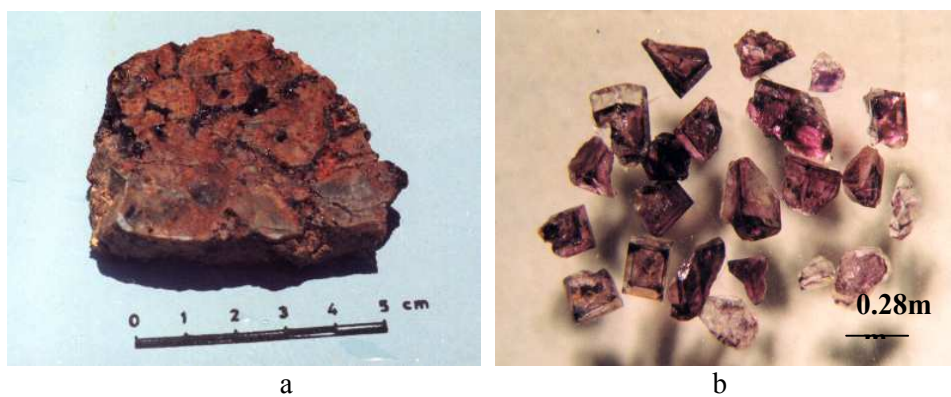

Fig. 2. a- Close-up photograph showing El-Missikat radioactive fluorite-bearing granite. b- Separated blue to violet radioactive fluorite crystals. Binocular microscope

## EXPERIMENTAL METHODS

For the purpose of the present study a technological bulk composite sample weighing ~15 kg representing El-Missikat radioactive fluorite-bearing granite was used. The latter was subjected to the conventional mineral separation procedures namely; disintegration, sizing and heavy liquid separation by bromoform ( $2.85 \text{ gm/cm}^3$ ) to estimate the heavy mineral content of each size fraction. The magnetic properties of the studied heavy mineral fractions was investigated using Frantz Isodynamic separator.

The physical beneficiation applied in the present study mainly consists of comminution and concentration processes. The latter were carried out using the laboratory wet Wilfely shaking table (No.13) and the Carpco high intensity lift-type magnetic separator Model MLH (13) III-5 for gravity and magnetic separation respectively. Uranium content of the various size fractions and their concentrates was determined using gamma spectrometric analysis.

## PRELIMINARY INVESTIGATION

A preliminary crushing test was carried out to reduce the size of the head sample to pass 1.00 mm screen for the liberation investigation. The deslimed fraction was dried and fractionated using a set of screens starting from 1.00 mm down to 0.045. Microscopic examination were carried out for the various size fractions.

It was found that the size fraction (- 0.800 +0.045) mm can be considered as the best grain size for good liberation for the radioactive fluorite and also suitable for the used mineral separation techniques. Heavy minerals mineralogy revealed that the content of the accessory minerals in the studied granitic sample amount to about 20%. Radioactive blue to violet fluorite (Fig. 2b) represents about 90% of the obtained heavy fractions and the rest are minor amounts of magnetite, hematite and mica.

A representative quantity of the total bulk heavy mineral fraction was obtained and subjected to magnetic separation using hand magnet in order to remove the magnetite. A proper magnetite free - feed was then prepared and subjected to magnetic separation using the Frantz Isodynamic separator (L-I). The purpose was to determine the behaviour of each heavy mineral during various magnetic field intensities. The setting of the separator during this study was ( $20^\circ$ ) forward slope and ( $5^\circ$ ) side slope. The obtained results shown in Table 1 revealed that the majority of fluorite crystals (92.75%) are concentrated as non-magnetic fraction at 1.5 amperes. About 7.25% of the total fluorite were attracted at magnetic fractions mainly due to the presence of iron oxide inclusions in these crystals.

It is quite clear that the difference in the magnetic susceptibilities between fluorite and other heavy minerals (magnetite, hematite and mica) would constitute the basis for their final magnetic separation. On the other hand, differences in the specific

gravities between the studied heavy minerals and the associated gangue minerals would render the gravitative concentration by shaking table as an efficient tool for their primary separation.

Table 1. Cummulative percent of individual minerals separated as magnetic fractions at different current intensities. Frantz Isodynamic Separator at setting of 20° forward slope and 5° side slope

Current (A) Mineral	0.2	0.5	0.7	1.0	1.2	1.5	Non-mag. 1.5
Fluorite	0.30	0.70	1.20	1.35	4.00	7.25	100.00
Hematite	3.50	96.40	100.00	-	-	-	-
Mica	100.00	-	-	-	-	-	-

## SAMPLE PREPARATION

Preparation of a suitable feed for the separation is very useful for attaining the maximum efficiency of the used equipment. The size of the separated particles is the most important factor affecting separation. This matter has been discussed by several authors (Taggart 1944; Jones 1959; Pryor 1974 and Gaudin 1980). According to Wills (1979), the correct degree of liberation is the key to the success in mineral processing. Controlled comminution operation (crushing and grinding) was carried out on representative bulk sample collected from El-Missikat shear zone (assaying 0.1950% U) in order to reduce the size of the head sample to pass 5.0mm screen. This has been achieved by applying a combination of jaw crushers and a roll mill crusher. The oversized (+5 mm) fraction was recycled to the secondary jaw crusher. The under-size (-5 mm) fraction was fed to a roll mill crusher followed by screening at 0.8 mm. The +0.800 mm fraction was recycled to the roll mill while the under size (-0.800 mm) was deslimed using a desliming cone. The deslimed size fraction (-0.800 mm) was dried and screened using a set of screens represented by (0.800, 0.600, 0.400, 0.200, 0.045 mm) screens. The latter was chosen in the light of liberation investigation and to save the majority of fluorite crystals in the liberation size fraction. The size fractions were collected, weighed and representative portions from each fraction was subjected to uranium determination using gamma spectrometric analysis. The sequence of processes followed in the crushing and liberation of the studied samples is presented in the flowsheet (Fig. 4). The obtained results of size analysis and the distribution of uranium in different size fractions are given in Table 2.

Both the -0.045 mm and slimes fractions contained 13.52% of the total uranium in the original sample. The obtained results reveal that about 86.48% from the original uranium present in the original sample was saved within 90.20% by weight. Also, these results indicate that the crushing operation was successful for saving the majority of radioactive fluorite within the deslimed size fraction (-0.800 +0.045).

Table 2. Granulometric analyses and uranium distribution among the various size fractions of El-Missikat radioactive fluorite-bearing granite

Size (mm)	Wt %	Assay eU%	Distribution eU%
-0.800 +0.600	20.92	0.1680	18.02
-0.600 +0.400	22.95	0.1790	21.07
-0.400 +0.200	30.35	0.1950	30.35
-0.200 +0.045	15.98	0.2080	17.04
Deslimed -0.600 +0.045	90.20	0.1870	86.48
-0.045 +Slimes	9.80	0.2690	13.52
Original	100.00	0.1950	100.00

## GRAVITATIVE SEPARATION

In order to reduce the bulk light gangue minerals from the deslimed size fractions and attain clean concentrate for each size fraction, the deslimed size fractions (-0.800 + 0.600 mm), (-0.600 + 0.400 mm) and (-0.200 + 0.045 mm) were separately fed to the Wilfely shaking table to obtain a primary concentration.

Table 3. Assay and material balance of the various products of gravitative separation

Size (mm)	Products	Wt%	Assay eU%	Distribution eU%
- 0.800 +0.600	Concentrate	3.66	0.8550	15.95
	Tails	17.26	0.0233	2.07
	Feed	20.92	0.1680	18.02
- 0.600 +0.400	Concentrate	4.15	0.8920	18.98
	Tails	18.80	0.0217	2.09
	Feed	22.95	0.1790	21.07
- 0.400 +0.200	Concentrate	5.61	0.9900	28.48
	Tails	24.74	0.0148	1.87
	Feed	30.35	0.1950	30.35
- 0.200 +0.045	Concentrate	3.06	1.0250	16.08
	Tails	12.92	0.0145	0.96
	Feed	15.98	0.2080	17.04

This operation was optimized by using less feed, less water, less tilt as much as possible, shorter length of stroke beside a low speed of the deck. The obtained cleaner concentrates were mainly composed of fluorite, iron oxides and mica. The efficiency of tabling was found to increase by decreasing the size range of the feed.

The results of the tabling operations shown in Table 3 and Table 5 reveal that the final concentrates of tabling operations containing 0.9418% U with a recovery of 91.92% in 18.27% by weight out of the deslimed size fraction (-0.800 +0.045) feed having 0.1870% U.

### MAGNETIC SEPARATION

The tabling concentrate of each size fraction was then subjected to the laboratory Carpco high intensity lift-type magnetic separator Model MLH (13) III-5 in order to obtain pure concentrates of radioactive fluorite. In this type of dry separator, the magnetic materials are lifted magnetically up against gravity in comparison to other separators that have gravity operating in the same general direction as magnetic force. This separator utilizes a vibratory feeder to transport the feed horizontally through an adjustable magnetic field zone where the magnetic force acting on the particles is perpendicular upwards. The advantage of this principle is a production of high purity magnetic products and also separation of more than one magnetic materials. The principles and gap adjustment of the used separator is shown in Figure 3.

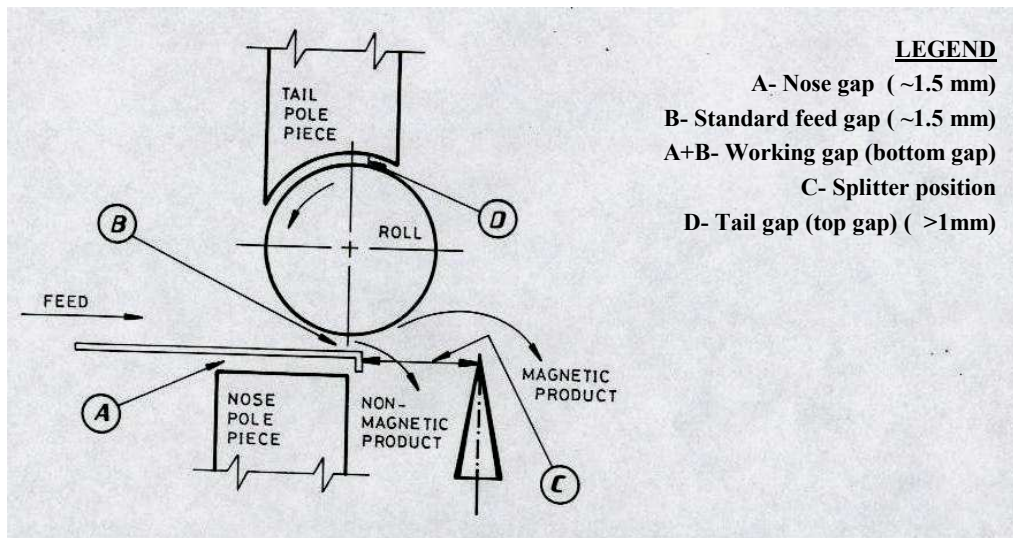

Fig. 3. Gap adjustment diagram for the high intensity lift-type magnetic separator (Carpc), Model MLH (13) 111-5

Magnetic separation was achieved at a magnetic field current of 1.0 amp. The speed of the roll and the feed rate were adjusted at 50 rpm and 200g/min respectively. The air gap between the induced roll and the feed plate was 1.5 cm. The dividing splitter was controlled visually. The obtained results in Table 4 indicated that the final non-magnetic concentrate of radioactive fluorite assays up to 1.0274% U with a recovery of 99.75% in 91.32% by weight out of feed having 0.9418% U.

Table 4. Assay and material balance of the different products of magnetic separation for the concentrates of tabling.

Size (mm)	Products	Wt%	Assay, U%	Distribution, U%
-0.800 +0.600	Magnetic fr.	0.37	0.0310	0.06
	Non mag. fr.	3.29	0.9420	15.89
	Concentrate of tabling	3.66	0.8550	15.95
-0.600 +0.400	Magnetic fr.	0.38	0.0280	0.05
	Non mag. fr.	3.77	0.9800	18.93
	Concentrate of tabling	4.15	0.8920	18.98
-0.400 +0.200	Magnetic fr.	0.45	0.0230	0.05
	Non mag. fr.	5.16	1.0750	28.43
	Concentrate of tabling	5.61	0.9900	28.48
-0.200 +0.045	Magnetic fr.	0.23	0.0230	0.04
	Non mag. fr.	2.83	1.1050	16.04
	Concentrate of tabling	3.06	1.0250	16.08

Table 5. Material balance of the proposed flowsheet for upgrading El-Missikat radioactive fluorite

Products	Wt%	Assay, U%	Distribution, U%
<b>1) Desliming and sizing:</b>			
-0.800 +0.045 mm	90.20	0.1870	86.48
Slimes and -0.045 mm	9.80	0.2690	13.52
Original (Head Sample)	100.00	0.1950	100.00
<b>2) Gravitative separation:</b>			
Final Concentrates of Tabling	16.48	0.9418	79.49
Final Tails of Tabling	73.72	0.0185	6.99
-0.800 +0.045 mm	90.20	0.1870	86.48
<b>3) Magnetic separation:</b>			
Final fluorite Concentrates (non-magnetic)	15.05	1.0274	79.29
Final magnetic fraction	1.43	0.0265	0.20
Final concentrates of Tabling	16.48	0.9418	79.49

A material balance for the different processes is shown in Table 5. The final non-magnetic fluorite concentrate contains up to 1.0274% U with a final recovery of 79.29% in a weight of 15.05% out of the original sample assays 0.1950% U. A schematic sequence of the processes followed in the upgrading operations is presented in the form of a proposed flowsheet in Figure 4.

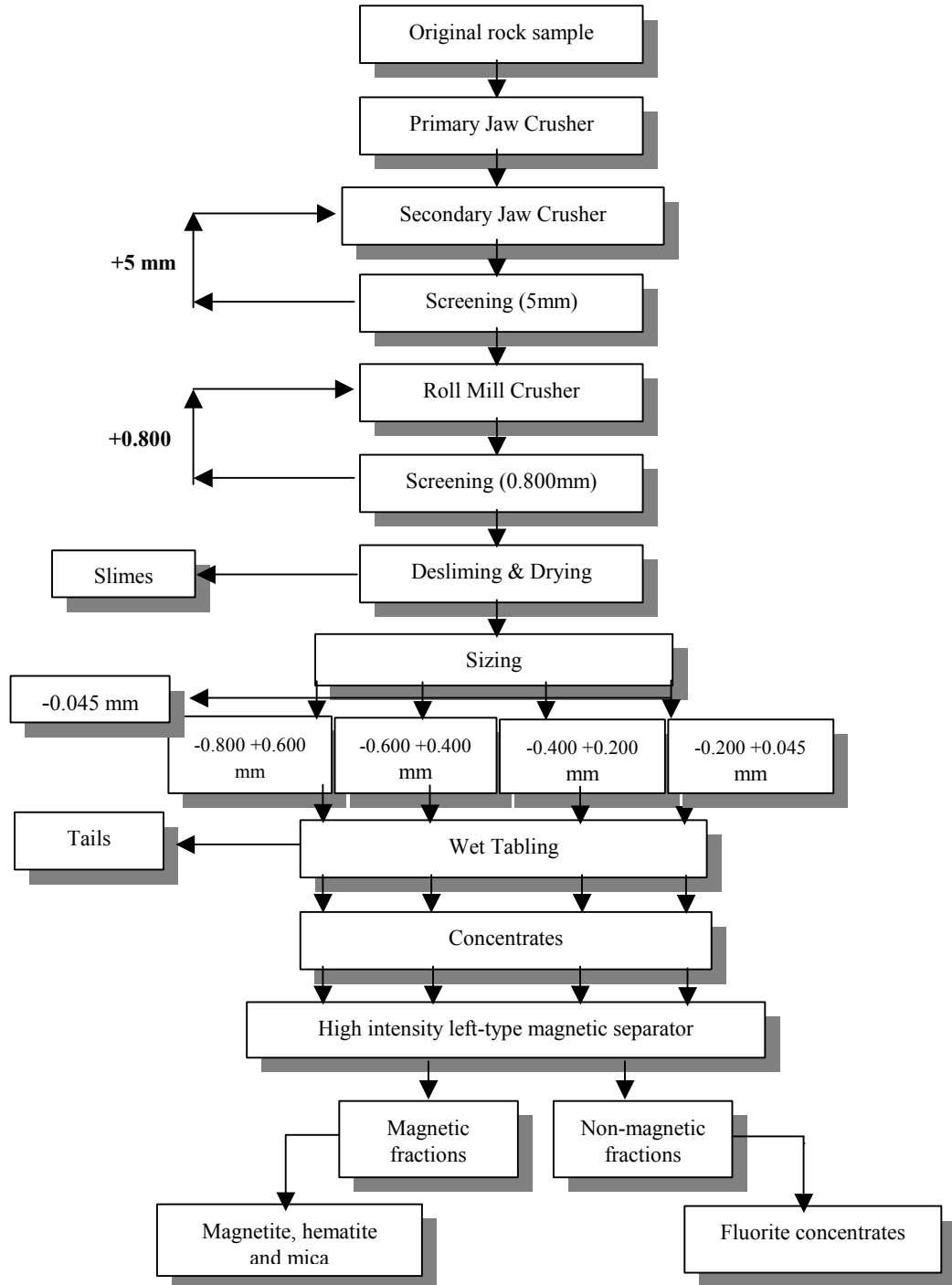

Fig. 4. A proposed flowsheet for upgrading radioactive fluorite from El-Missikat fluorite-bearing granite



## CONCLUSIONS

Mineralogy of the studied radioactive fluorite-bearing granite from El-Missikat area revealed that radioactive fluorite represent about 20% by the weight of the original rock sample. Radioactive blue to violet fluorite represent about 90% of the total accessory heavy minerals. Gravitative and magnetic separation were used respectively to upgrading the radioactive fluorite. The final non-magnetic fluorite concentrate contains up to 1.0274% U with a final recovery of 79.29% in a weight of 15.05% out of the original sample assays 0.1950% U.

## REFERENCES

- ABU DEIF, A., (1985): Geology of uranium mineralization in EL Missikat area, Qena-Safaga road, Eastern Desert, Egypt. M.Sc. Thesis, Al Azhar University, 109pp.
- ABU DEIF, A., AMMAR, S. E. MOHAMED, N. A. (1997): Geological and geochemical studies of black silica at El-Missikat pluton, Central Eastern Desert, Egypt. Proc.Egypt. Acad. Sci. 47: 335-346.
- BAKHIT, F. S., (1978): Geology and radioactive mineralization of Gabal EL-Missikat area, Eastern Desert, Egypt. Ph.D. Thesis, Faculty of Science, Ain Shams Univ., Cairo. 289 p.
- GAUDIN, A. M. (1980): Principles of mineral dressing, TATA McGraw Hill publishing Co. Ltd, New Delhi.
- HUSSEIN, H. A., HASSAN, M. A., EL-TAHIR, M. A., ABU DEIF, A. (1986): Uranium bearing siliceous veins in younger granites, Eastern Desert, Egypt. IAEA, TECDOC 361, 143-157.
- JONES, M. P. (1959): Mineral dressing tests on the extraction of collumbite and other heavy minerals from the Olegi younger granite, Rec. Geol. Surv. Nigeria (published in 1960).
- PRYOR, E. J. (1974): Mineral processing. Applied Science publishers Limited. Third Edition, London.
- RASLAN, M. F. ( In preparation): Mineralogical and geochemical characteristics of uranium-rich fluorite in El-Missikat mineralized granite, Central Eastern Desert, Egypt.
- TAGGART, A. F. (1944): Hand book of mineral dressing and industrial minerals. John Wiley and Sons, Inc. New York, London, Sedney.
- WILLS, B. A. (1979): Mineral processing technology, Pergamon Press, Oxford, New York, Toronto, Sydney, Paris, Frankfurt.

**Raslan M.F.,** *Wzbogacanie fluorytu bagatego w uran ze złoza El-Missikat o mineralizacji granitowej z pustyni w centralo-wschodniej części Egiptu.* Physicochemical Problems of Mineral Processing, 42 (2008), 185-194 (w jęz. ang)

Występowanie i właściwości mineralogiczne fluorytu o wysokim stopniu radiacji, ze złoza w El-Missikat, były dyskutowane we wcześniejszych pracach. Zawartość uranu w próbce pobranej do badań nad fluorytem wynosiła 1950 ppm. Obecność uranu w strukturze fluorytu była ewidentna. Kryształy fluorytu wykazywały znaczą radioaktywność. Badania mikroskopowe, prowadzone pod kątem akcesoryjnych minerałów ciężkich, potwierdziły, że radioaktywny fluoryt reprezentuje około 20 % wagowych pobranej próbki skalnej. Również, radioaktywny fluoryt stanowił około 90% całości akcesoryjnych minerałów ciężkich obok tlenków żelaza i miki. Fizyczne wzbogacanie radioaktywnego fluorytu zostało przeprowadzone stosując techniki grawitacyjne i separacji magnetycznej. Przy zastosowaniu optymalnych

warunków, jest możliwość wzbogacenie uranu do poziomu 1.0274% z końcowym uzyskiem 79.29 % (wag). Wychód masowy wynosi 15.05%, zaś zawartość uranu w nadawie wynosiła 0.1950%.

*słowa kluczowe: uran, radioaktywny fluoryt, minerały ciężkie, granit, wzbogacanie*